

PS-FL9

SERVICE MANUAL

US Model
AEP Model

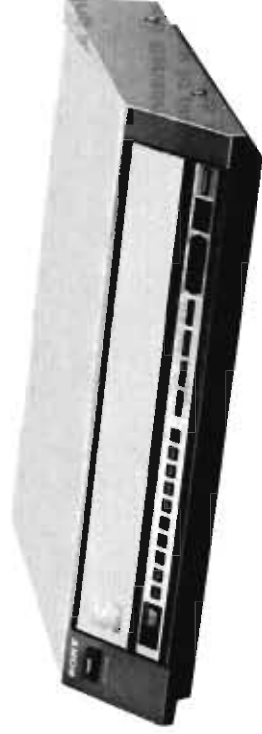

Photo: Black Type

SPECIFICATIONS

Turntable	
Platter	29 cm (11 ¹ / ₂ in.), aluminum-alloy diecast
Motor	Linear torque BSL (brushless and slotless) motor
Drive system	Direct drive
Control system	Quartz lock servo control system
Speed	33 ¹ / ₃ rpm, 45 rpm
Wow and flutter	0.03% (WRMS) *, 0.035% (WRMS) ±0.045% (DIN)
Signal-to-noise ratio	75 dB (DIN-B)
Automatic system	Loading, lead-in, return, reject, repeat, tonearm up/down, record size selection, RMS, AMS, skip
Load characteristics	0% up to 1.5 g tracking force (at lead-in groove of a record) Within ±0.003%
Speed deviation	
Tonearm	
Type	Linear tracking tonearm
Pivot-to-stylus length	75 mm (3 in.)
Tracking error	±0.1°
Tracking force adjustment range	1.25 ±0.25 g plug-in type, 6 g
Cartridge XL-250G	
Type	Moving magnet type
Frequency response	10 Hz to 20,000 Hz
Channel separation	23 dB at 1 kHz
Output voltage	5 mV at 1 kHz, 5 cm/sec., 45°
Load impedance	50 to 100 kilohms
Tracking force	1.0 to 1.5 g (1.25 g recommended)
Stylus	Sony ND-250G
Weight	6 g

General

Power requirements 120 V ac, 60 Hz (US model)
220 V ac, 50/60 Hz (AEP model)
Power consumption 13 W (US model)
14 W (AEP model)

Dimensions

Approx. 430 x 96 x 382 mm (w/h/d)
(17 x 3⁷/₈ x 15¹/₄ in.)
including projecting parts and controls

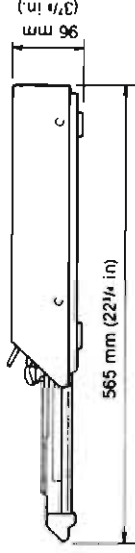

Weight

Approx. 7.6 kg (16 lbs 12 oz), net
Approx. 9.4 kg (20 lbs 12 oz), in shipping carton

* This new measuring method concerns only the turntable assembly, including the platter. It excludes wow and flutter caused by the tonearm, the cartridge or the record. Measured by obtaining signal from magnetic pick-up head.

SAFETY-RELATED COMPONENT WARNING!!

COMPONENTS IDENTIFIED BY SHADING AND MARK
▲ ON THE SCHEMATIC DIAGRAMS AND IN THE
PARTS LIST ARE CRITICAL TO SAFE OPERATION.
REPLACE THESE COMPONENTS WITH SONY PARTS
WHOSE PART NUMBERS APPEAR AS SHOWN IN THIS
MANUAL OR IN SUPPLEMENTS PUBLISHED BY SONY.



STEREO TURNTABLE SYSTEM

SONY®

AUD

FEATURES

Unique modular turntable system

When you touch the OPEN/CLOSE button the turntable module will smoothly slide out. Other audio components can be positioned on top of the turntable cabinet.

Servo-controlled linear tracking tonearm

Compared with a pivoted tonearm, a linear tracking arm has a very small tracking error (which means greatly reduced harmonic distortion) and almost no pressure on the inside wall of the groove (which means improved tracking ability and channel separation).

Programmed play

The RMS (Random Music Sensor), AMS (Automatic Music Sensor) and skip functions allow you to program record play as you like.

RMS : for playing the selections on one side of the record in a desired sequence.

AMS : for starting record play from the desired selection.

Skip function : for skipping selections to the desired selection.

A microcomputer controls four motors

The movement of the turntable, the tonearm and the turntable module is controlled by a microcomputer. When you press the START/STOP button, the module will close, the turntable will rotate and the tonearm will lower onto the record. The tonearm up/down is controlled by its own linear motor to obtain quiet movement.

Fully automatic system

With the module closed, automatic record play and tonearm up/down are operated by the "feather-touch" function buttons on the front panel. The record size is automatically set by a photo-sensor system.

Muting system

A muting system activates when the tonearm is lifted and deactivates after the tonearm lowers onto a record so there is no need to turn the amplifier volume down every time a stylus is placed on a record.

Quartz lock servo system

The turntable maintains accurate and drift-free speed by referring to a frequency generated by a very stable quartz oscillator.

Linear torque BSL motor

Direct drive system with Sony's unique BSL (brushless and slotless) motor which has an extremely low noise level and whose smoothness virtually eliminates wow and flutter. Its high torque assures a quick start to 33 $\frac{1}{3}$ rpm after only a half revolution.

Synchronized operation with the Sony cassette decks

When the tonearm lowers onto the lead-in groove of a record, the cassette deck stand-by mode is released and the record mode assumed. This synchronized operation is possible with Sony cassette decks equipped with a remote control jack which is connected with the Sony RM-65 synchro remote control unit.

SAFETY CHECK-OUT (US Model)

After correcting the original service problem, perform the following safety check before releasing the set to the customer:

Check the antenna terminals, metal trim, "metallized" knobs, screws, and all other exposed metal parts for AC leakage. Check leakage as described below.

LEAKAGE TEST

The AC leakage from any exposed metal part to earth ground and from all exposed metal parts to any exposed metal part having a return to chassis, must not exceed 0.5 mA (500 microamperes). Leakage current can be measured by any one of three methods.

1. A commercial leakage tester, such as the Simpson 229 or RCA WT-540A. Follow the manufacturers' instructions to use these instruments.
2. A battery-operated AC milliammeter. The Data Precision 245 digital multimeter is suitable for this job.

3. Measuring the voltage drop across a resistor by means of a VOM or battery-operated AC voltmeter. The "limit" indication is 0.75 V, so analog meters must have an accurate low-voltage scale. The Simpson 250 and Sanwa SH-63Trd are examples of a passive VOM that is suitable. Nearly all battery operated digital multimeters that have a 2V AC range are suitable. (See Fig. A)

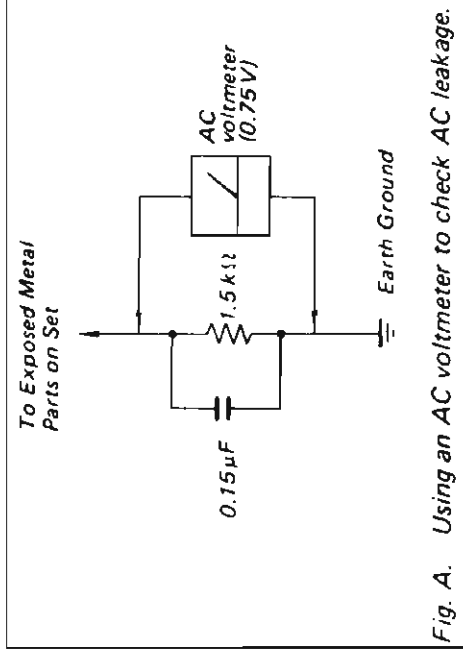
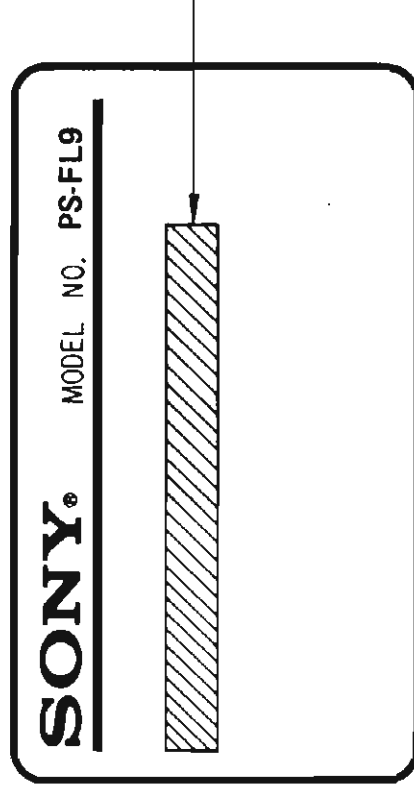

Fig. A. Using an AC voltmeter to check AC leakage.

MODEL IDENTIFICATION

— Specification Label —



US model: AC: 120 V ~ 60 Hz 13 W
AEP model: AC: 220 V ~ 50/60 Hz 14 W

NOTES ON REPAIR

— When removing the bottom plate —

- When POWER switch (S101) turns ON with bottom plate removed, loading motor (M701) continues to rotate and does not stop. But, it is not broken.

1. When POWER switch (S101) turns ON with TABLE END switch (SW501 or SW502) pressed, loading motor (M701) does not rotate.

2. When TABLE END switch (SW501 or SW502) is pressed according to the rotating direction of loading motor (M701), the motor stops even if the motor is rotating (See the figure below).

3. System control IC checks the condition of TABLE END switch by pressing ARM TRANSPORT (◁ , ▷), ARM LIFTER (▼ , ▲), START/STOP button.

When operation buttons are pressed, be sure to keep TABLE END switch (SW501 or SW502) pressed.

If not, key input can not be found.

loading motor
(M701)

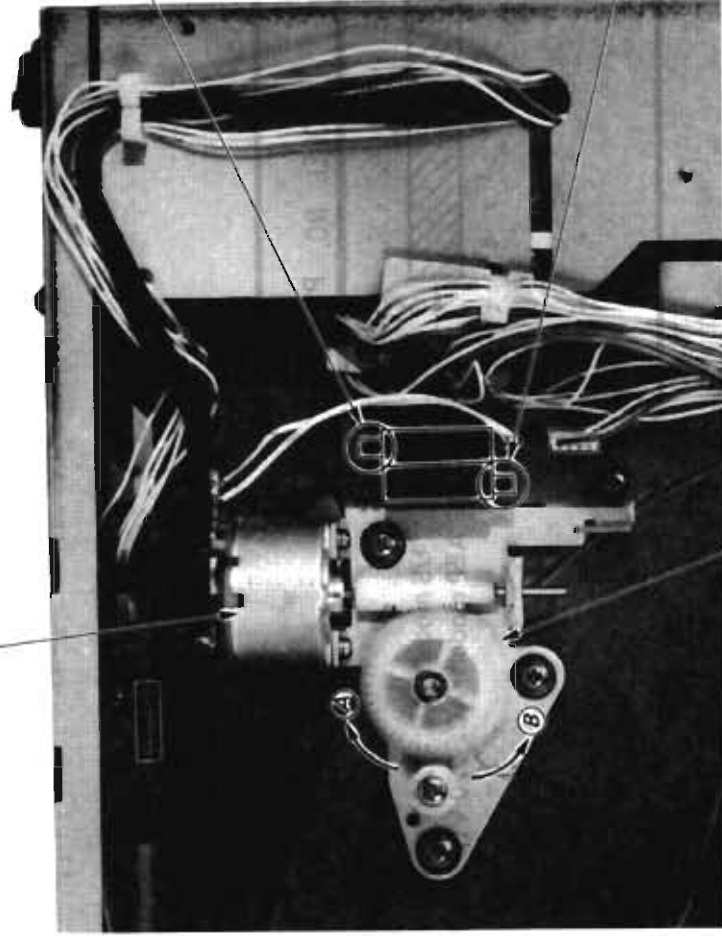

When worm wheel (A) is rotating in the direction of (B), press SW501 (close end det).

When worm wheel (A) is rotating in the direction of (A), press SW502 (open end det).

worm wheel (A)

REPAIR METHOD FOR HYBRID CIRCUIT BLOCK

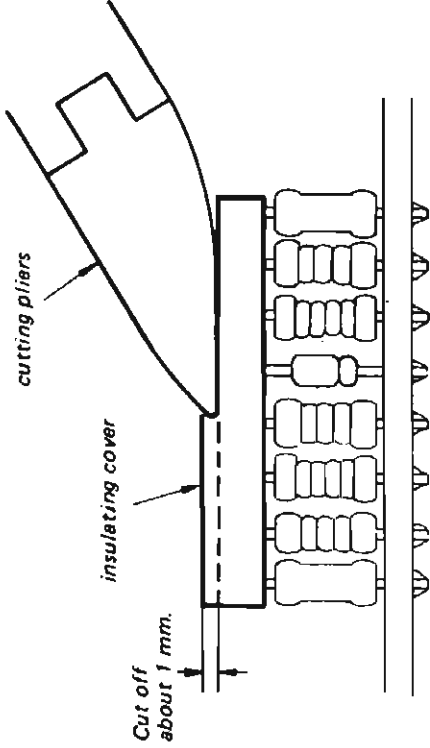

Using a cutting pliers, cut off the upper portion of the insulating cover about 1 mm, exposing the top of the connecting brackets.

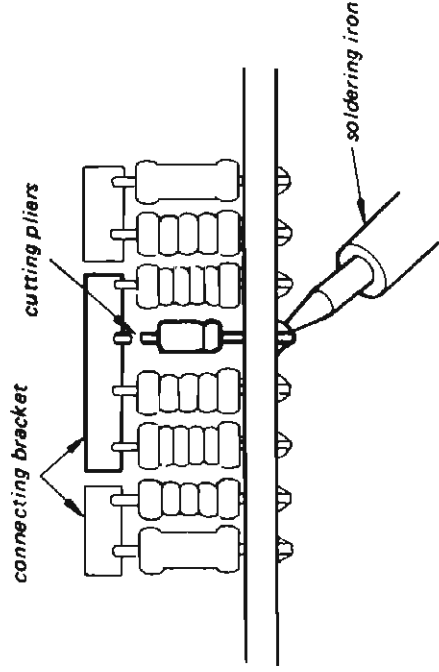
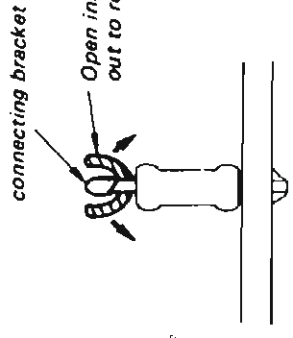

Cut off the lead of the defective part with cutting pliers. Remove solder and take out the defective part.

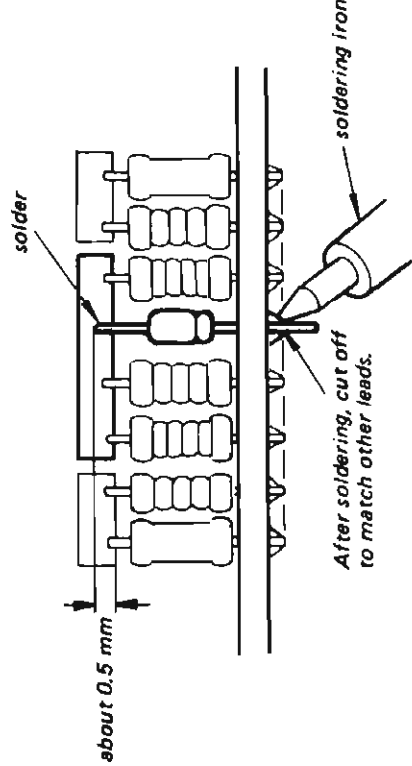

Insert the new part on the board and solder the lead to the board. Cut off the lead on the connecting bracket side so that it overlaps by about 0.5 mm, and solder to the connecting bracket.

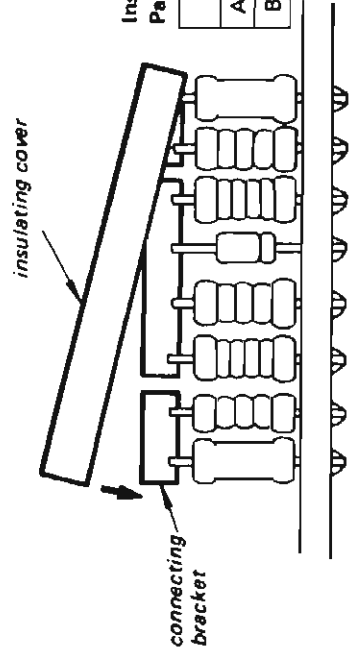

Open the insulating cover groove about 0.7 mm and place over the connecting brackets, positioning one end first.

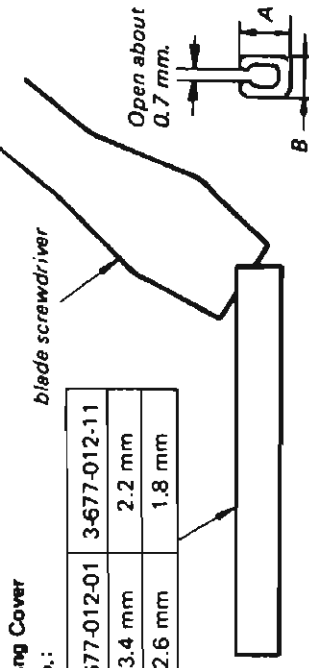

Insulating Cover
Part No.:

	3-677-012-01	3-677-012-11
A	3.4 mm	2.2 mm
B	2.6 mm	1.8 mm

FUNCTION OF CONTROLS

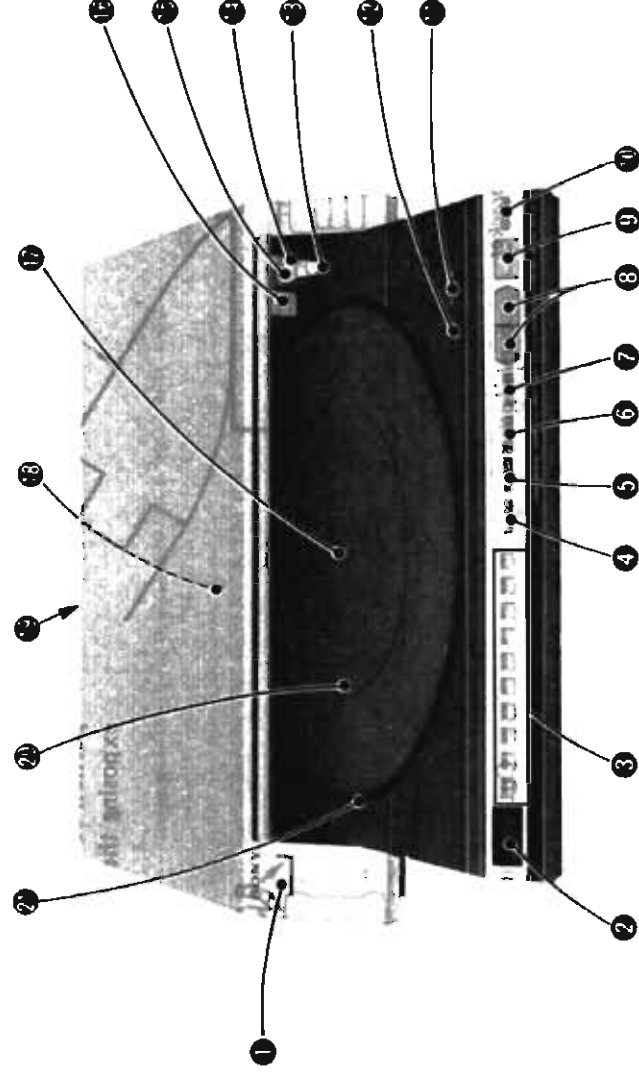

1 POWER switch

Depress to turn on the power. To turn the power off, press it again.

2 Display window

The number of the selection being played, the programmed selections for RMS play, etc. are displayed in this window.

3 RANDOM MUSIC SENSOR programming buttons and C (clear) button

Used for programming the selections to be played in the desired sequence. See "RMS play" on page 9.

4 SKIP button

Press this button to skip from the selection being played to the next selection. See "To skip to the desired selection during play" on page 8.

This button is also used for AMS (Automatic Music Sensor) play. See "AMS play" on page 7.

5 SPEED selector and indicators

When the power is turned on, the speed is automatically set to 33 $\frac{1}{3}$ rpm, and the "33" indicator lights up. Press this button when a 45 rpm record is to be played, and the "45" indicator lights up. Press it again for a 33 $\frac{1}{3}$ rpm record.

6 REPEAT button and indicator

Press this button to repeat play. Repeat play continues until this button is pressed to release it. During RMS play, only the programmed selections will be repeated in the programmed sequence.

7 \uparrow/\downarrow ARM LIFTER button

This button lifts and lowers the tonearm. When the tonearm is on the arm rest, this button is not operative.

8 ARM TRANSPORT buttons

To move the tonearm inward, press the \square button, and to move outward, the \square button. The tonearm is raised and continues to move while the button is pressed. The tonearm will stop when the button is released. For fine adjustments, press and immediately release the appropriate button.

9 START/STOP button and Indicator

Press to start the record playing. The indicator will light up. To stop during play, press it again.

This button is not operative while the turntable module is opening or closing.

10 OPEN/CLOSE button

With one touch of this button the turntable module automatically opens for loading a record. With another touch the module automatically closes.

11 SENSITIVITY selector

Normally set this selector to M. When the number of the selections detected is not correct, set the selector to either H or L. See page 10.

12 DP ADJUST (drop-point adjustment) opening

13 Cartridge

14 Cartridge locking screw

15 Tonearm

16 Tonearm position indicator

17 Center spindle

18 Photo detector

Detects the record size (30 cm, 25 cm and 17 cm) and how many selections are on a record, by searching for blank spaces between selections when the module closes. See page 10.

19 Synchro remote control jack (rear)

20 Rubber mat

21 Platter

RECORD PLAYING

AUTO PLAY

— To begin record play from the beginning of the record

This turntable's photo detector detects the record size: 30 cm (12 inch), 25 cm (10 inch) or 17 cm (7 inch), and the number of the selections on the record when the module closes. Therefore after turning the power on, be sure to press the OPEN/CLOSE button to open the module so that the detector is on standby.

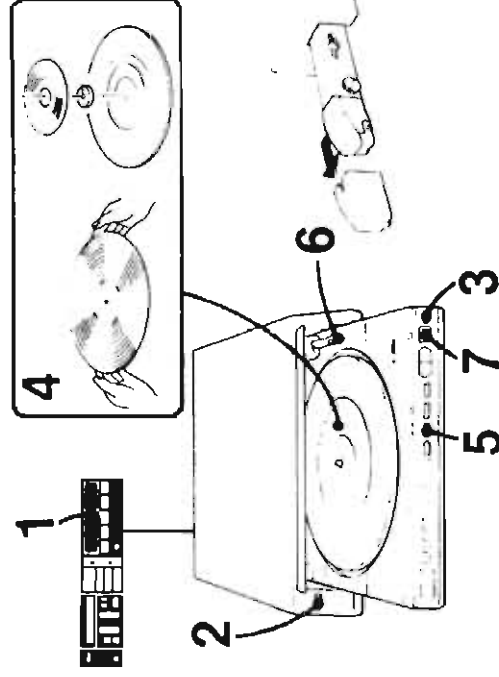

- 1 Turn on the amplifier and set the input selector to PHONO.
- 2 Depress the POWER switch (ON).
- 3 Press the OPEN/CLOSE button to open the module.
- 4 Place a record on the platter. For 45-rpm record playing, place the supplied 45-rpm adaptor.
- 5 For 45-rpm record playing, press the SPEED button to illuminate the "45" indicator.
- 6 Remove the stylus guard.
- 7 Press the START/STOP button. The module closes and play will begin. The indicator of the START/STOP button lights during play. The number of the selection being played is displayed in the display window.



When the tonearm reaches the end of the record, it will automatically return to the arm rest. Press the POWER switch to turn the unit off after the tonearm returns to the arm rest.

Notes

- If the turntable causes interference to radio and television reception, turn off the turntable or move the turntable away from the receiver.
- A badly warped record cannot be played because it will rub against the tonearm.
- Transparent records, records of an unusual shape or color (red or blue), or non-standardized records cannot be played automatically. To play these records, follow the instructions on page 8.
- Turn off the POWER switch after the tonearm returns to the arm rest. If the POWER switch is turned off while the tonearm is returning to the arm rest, when you press the POWER switch the next time the tonearm will return to the arm rest. While the tonearm is moving, the START/STOP button is not activated.

AMS (AUTOMATIC MUSIC SENSOR) PLAY

— To begin record play from the desired selection

- 1 Press the OPEN/CLOSE button to open the module, put on a record and select the correct record speed.
- 2 Press the SKIP button repeatedly until the number of the selection from which you want to start play is displayed. Each time the SKIP button is pressed, the number of the selection displayed increases by one, up to 15, then returns to 01.



Selection number

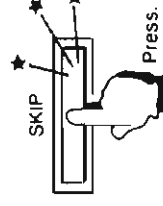

Press.

- 3 Press the START/STOP button. The module closes, the tonearm searches for the preset selection and play begins.

While searching



While playing



blink.

light up.

Note

If the selection number which does not exist (for example, "08" for a record which contains only 7 selections) is input, the "E" (error) indicator appears and flashes several times, then "00" is displayed. In this case, input an appropriate selection number.

MANUAL PLAY

— To begin record play at a particular point

Manual play is used:

- for beginning record play in the middle of a selection
- for playing a record which cannot be played automatically
- for playing a record with the module open

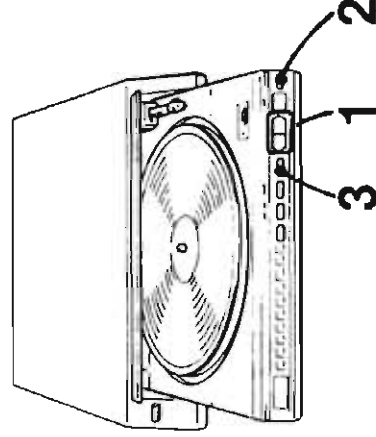

1 After proceeding from step 1 to 6 in "AUTO PLAY", press the ◀ or ▶ **ARM TRANSPORT** button to move the tonearm over the record to the desired point. At the desired point, release the button.

2 Press the **OPEN/CLOSE** button to close the module.

3 Press the **ARM LIFTER** button. Play will begin.

The number of the selection being played is displayed in the display window.

When the tonearm reaches the end of the record, it will automatically return to the arm rest. Press the **POWER** switch to turn the unit off after the tonearm returns to the arm rest.

Note

To play a record with the module open, press the **ARM LIFTER** button without pressing the **OPEN/CLOSE** button. In this case, the number of the selection being played is not displayed and the auto return function does not operate at the end of the record. Press the **START/STOP** button at the end of the record to return the tonearm to the arm rest.

TO LIFT UP THE STYLUS DURING PLAY

To lift the stylus from a record for a moment and then start playing from the same point, press the **ARM LIFTER** button. To lower the tonearm onto the record, press the **ARM LIFTER** button again.

TO STOP DURING PLAY

To stop playing and open the module, press the **OPEN/CLOSE** button. (When the module has opened, a touch of this button will close the module.)

You can stop play by pressing the **START/STOP** button instead of the **OPEN/CLOSE** button. In this case, the module will not move.

TO MOVE TO A DIFFERENT PART OF A RECORD DURING PLAY

Move the tonearm to the desired point of the record by pressing the **ARM TRANSPORT** buttons and then press the **ARM LIFTER** button to start play.

TO REPEAT PLAY

Press the **REPEAT** button either before or after starting play when the module is closed. The indicator of the **REPEAT** button lights up. To cancel the repeat play, press the **REPEAT** button again. (The indicator goes off.)

To stop during repeat play, press the **OPEN/CLOSE** button or the **START/STOP** button.

The indicators of the **REPEAT** and **START/STOP** buttons go off and the repeat function is cancelled. The module will open only when the **OPEN/CLOSE** button has been pressed.

Note

Repeat play cannot be activated while the module is open or while the tonearm is moving.

TO SKIP TO THE DESIRED SELECTION DURING PLAY

—Using the SKIP function

1 Press the **SKIP** button repeatedly during play until the number of the desired selection is displayed.

Each time the **SKIP** button is pressed, the next selection in advance is displayed, and when the last selection has been selected, the display reverts to 01.

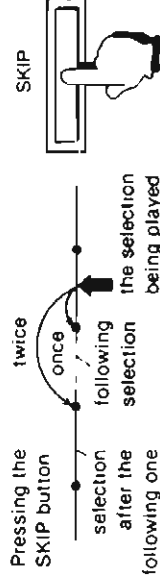

The tonearm will lift up, search for the preset selection and play will start automatically.

Note

The **SKIP** function is inoperative while the tonearm is in the raised position or while the record is being played with the module open.

RMS (RANDOM MUSIC SENSOR) PLAY

You can play selections on one side of the record in the desired sequence, which has been programmed using the RANDOM MUSIC SENSOR buttons.

- 1 Press the OPEN/CLOSE button to open the module, put on a record and select the record speed.
- 2 Press the RANDOM MUSIC SENSOR buttons in the sequence in which you want to listen to the selections.
Each time the RANDOM MUSIC SENSOR button is pressed, the selected number is displayed once in the right position in the display window, immediately moves to the left position, and the cursor blinks in the right position to indicate another selection can be programmed.

Up to 15 selections can be programmed.

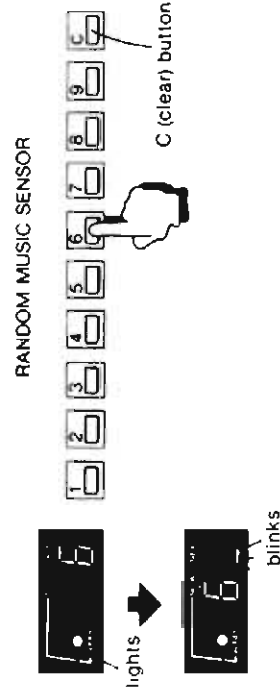

- 3 Press the START/STOP button.

The module closes and play begins from the first-programmed selection. The RMS indicator lights during RMS play.

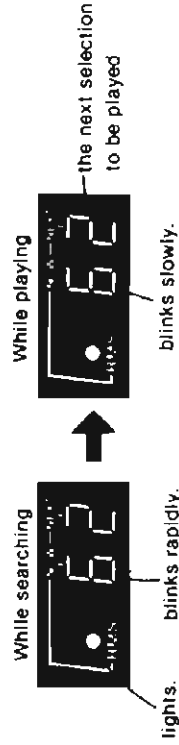

At the end of the last-programmed selection, the tonearm will return to the arm rest automatically.

If you wish to play the same selections in the same sequence again, press the START/STOP button.

To change the programmed sequence

Press the C button when the tonearm is on the arm rest. The display will change to 00 and the programmed sequence will be erased. Then press the RANDOM MUSIC SENSOR buttons again in the desired sequence.

To add to the programmed sequence

Simply press the required RANDOM MUSIC SENSOR buttons during RMS play after some selections have been played. (While the tonearm is searching to a selection, the RANDOM MUSIC SENSOR buttons are not operative.)

Automatic editing function of the RMS program

If a selection number which does not exist on the record is selected with the module open, that number will be erased automatically when the module closes.

For example, if you have pressed the 6, 2, 8, 5 and 7 RANDOM MUSIC SENSOR buttons in that order, for a record containing only 6 selections, numbers 8 and 7 will be erased when the module closes and the 6th, 2nd and 5th selections will be played.

If an incorrect RANDOM MUSIC SENSOR button is pressed with the module closed, the number of the button will not be displayed. This is an automatic editing function of the RMS program.

If the pressed RANDOM MUSIC SENSOR buttons are all incorrect, the "E"(error) indicator will flash several times, or the display will not change from 00.

To cancel the RMS program

Press the RANDOM MUSIC SENSOR buttons or the OPEN/CLOSE button during play, or press the C button when the tonearm is on the arm rest. The display will change to 00 and the programmed sequence will be erased.

TO LIFT UP THE STYLUS DURING RMS PLAY

To lift up the stylus for a moment and then start playing from the same point, press the ARM LIFTER button. To lower the tonearm onto the record, press the ARM LIFTER button again.

TO STOP DURING RMS PLAY

Press the START/STOP button. The tonearm will return to the arm rest.

When the START/STOP button is pressed again, the RMS play will restart from the beginning.

TO SKIP SELECTIONS DURING RMS PLAY

Press the SKIP button during play. Each time the SKIP button is pressed, the next selection ahead is played.

TO REPEAT RMS PLAY IN THE PROGRAMMED SEQUENCE

Press the REPEAT button either before or after starting RMS play. At the end of the last-programmed selection, the tonearm will return to the first-programmed selection automatically, then play will restart.

To stop during repeat play, press the REPEAT button. When the last-programmed selection has been played, the tonearm will return to the arm rest and repeat function will be cancelled.

If you press the START/STOP button during repeat play, play will stop immediately, the tonearm will return to the arm rest and the repeat function will be cancelled.

Error indicator



The "E" (error) indicator flashes several times and the display will change to 00 in the following cases.

- When the START/STOP button is pressed, but there is no record on the platter.
- When inappropriate selection numbers are set for AMS or RMS play with the module open, and the START/STOP button is pressed.
- When the OPEN/CLOSE button is pressed while the module is closing and the same button is pressed again before the module has opened completely, then the START/STOP button is pressed.

HOW RECORD SIZED AND SELECTIONS ARE DETECTED

When the module closes, the photo detector searches over the record to detect the record size (30 cm, 25 cm or 17 cm) and sense how many selections are on the record, by detecting the blank spaces between selections. The selection number indicator changes rapidly from 01 to the number of the selection contained on the record. Up to 15 selections can be counted. The data is input into the memory of the microcomputer incorporated. This data will be erased from the memory when the OPEN/CLOSE button is pressed to open the module or when the POWER switch is turned off.

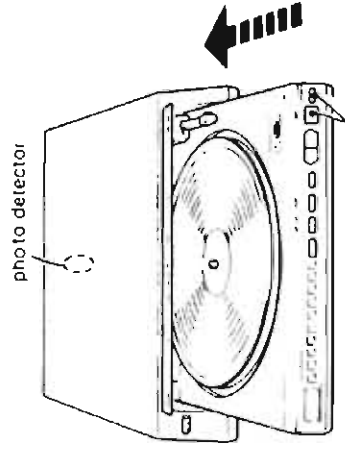

Press START/STOP or
OPEN/CLOSE

Note

If the OPEN/CLOSE button is pressed while the module is closing and the same button is pressed again before the module has opened completely, the record size and selections will not be detected and the "E" (error) indicator will flash several times when the START/STOP button is pressed later. In this case, press the OPEN/CLOSE button to open the module completely and press it again to close the module.

SENSITIVITY selector

Since the photo detector searches for the blank spaces on a record, it cannot operate correctly if the blank spaces and music grooves are not in good condition. As a result, the RMS, AMS and skip functions may malfunction.

If the number of the selections detected is different from the number of the selections actually existing, change the position of the SENSITIVITY selector to either H (high) or L (low).

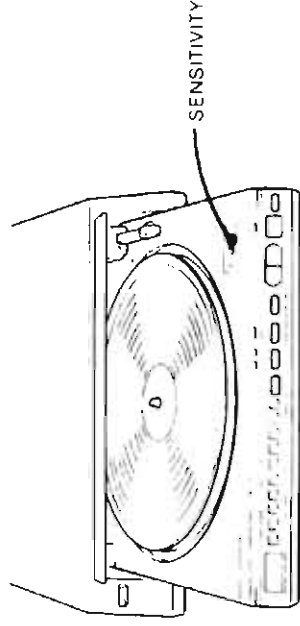

Why too few selections are detected :

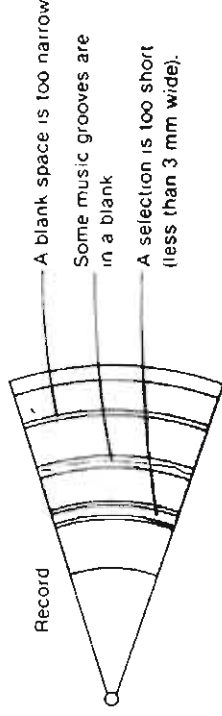

Why too many selections are detected :

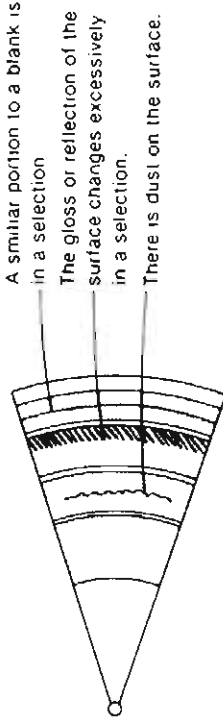

Special records

The photo detector cannot operate with transparent records, non-standardized records and records of an unusual shape or color (red or blue). Play these record manually, referring to "Manual play" on page 8.

REPLACING THE STYLUS

Replace the stylus after about 400 hours of use because using a worn stylus will damage records. An ND-250G replacement stylus is available at your Sony dealer.

The **TIP** label indicates that a cartridge is a standardized plug-in type.

- 1 Press the OPEN/CLOSE button to open the module.
- 2 Press the **ARM TRANSPORT** button to move the tonearm toward the center spindle.
- 3 Remove the cartridge locking screw and unplug the cartridge.

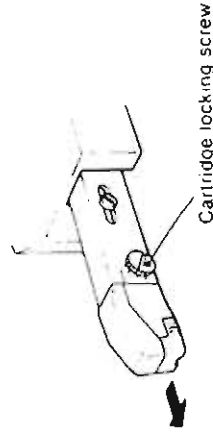

- 4 Detach the stylus assembly and insert a new stylus into the cartridge.



- 5 Plug the cartridge into the tonearm and tighten the cartridge locking screw firmly.

The screw cannot be inserted from this side.

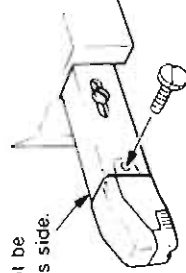

- 6 Press the **ARM TRANSPORT** button to move the tonearm to the arm rest.

- 3 Check if the drop-point is correctly adjusted by lowering the tonearm to the beginning of a selection in the middle of the record, using the AMS function. (Checking the drop-point for the first selection is not sufficiently accurate.) If the drop-point is correct for one selection, it will also be correct for all the selections.

TRACKING FORCE FINE ADJUSTMENT

The tracking force has been correctly adjusted at the factory. Make fine adjustment only when the tracking force is so light that the stylus skips grooves.

- 1 Press the OPEN/CLOSE button to open the module.
- 2 Press the **ARM TRANSPORT** button to move the tonearm toward the center spindle.
- 3 Slide the tracking force adjustment lever.

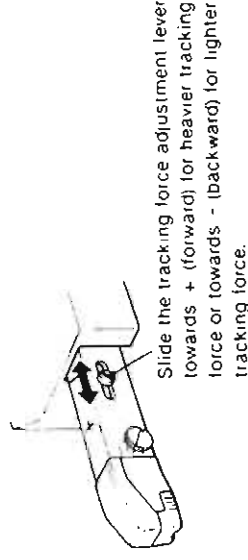

TO NEARM DROP-POINT ADJUSTMENT

The tonearm's drop-point during auto play, AMS play or RMS play has been adjusted at the factory. Adjust this if the stylus does not lower correctly at the beginning of the desired selection.

- 1 Press the OPEN/CLOSE button to open the module.
- 2 Insert the supplied screwdriver into the DP ADJUST opening. To move the drop-point inward, turn the screw counter clockwise (towards IN).

To move the drop-point outward, turn the screw clockwise (towards OUT). Do not turn it so far clockwise that the stylus tip cannot make contact with the record.

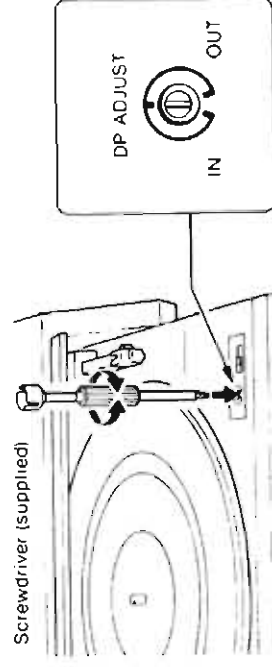

MEMO

A series of 25 horizontal dotted lines for writing.

SECTION 1 OUTLINE

1-1. BLOCK DIAGRAM

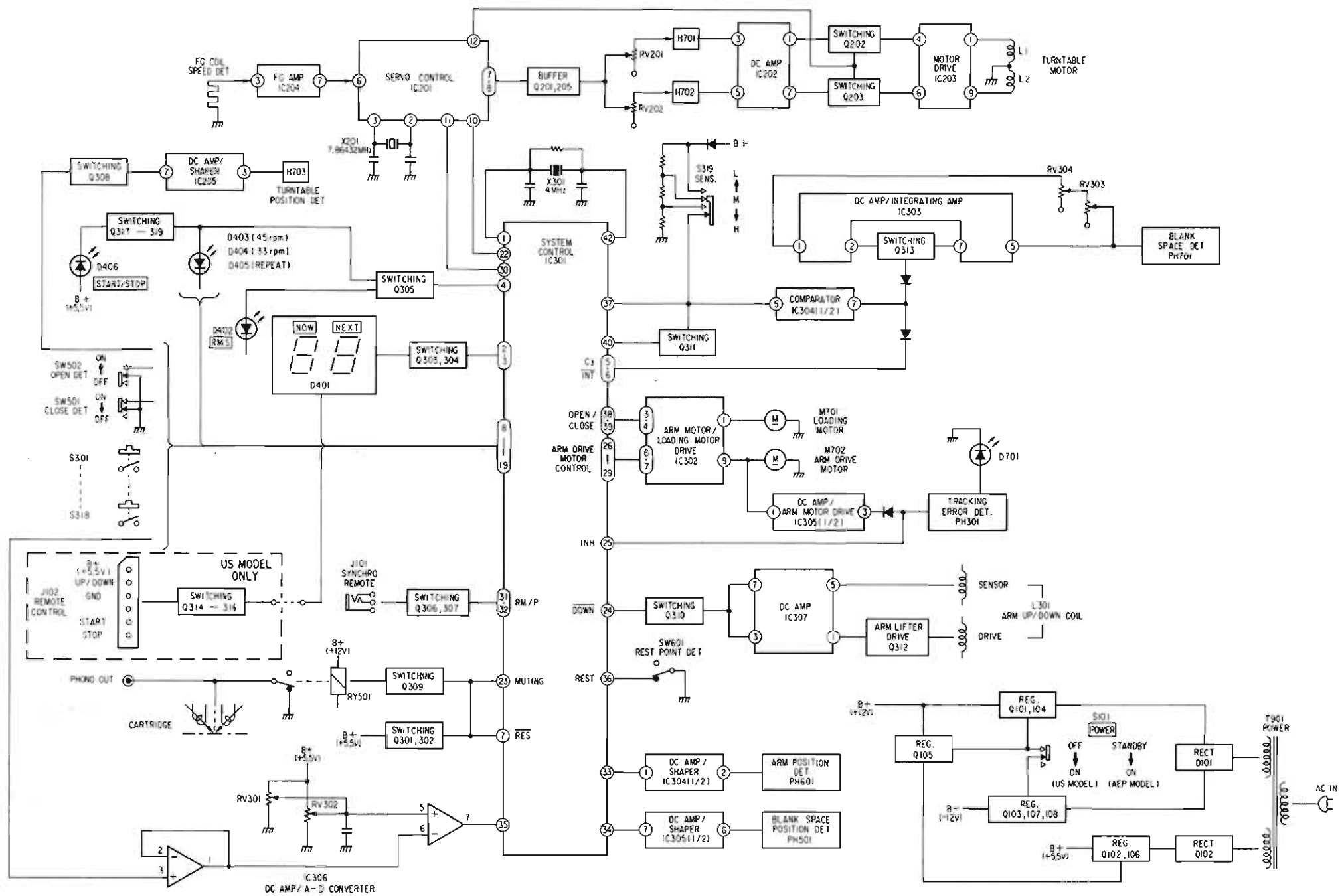

SECTION 2 DISASSEMBLY

2-1. REMOVAL

Note: Follow the disassembly procedure in the numerical order given.

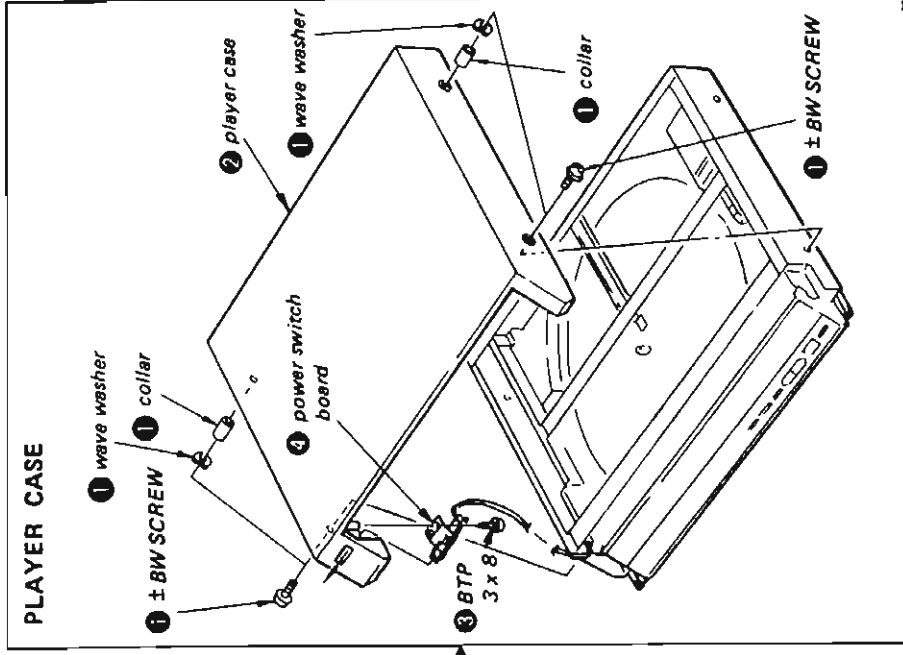
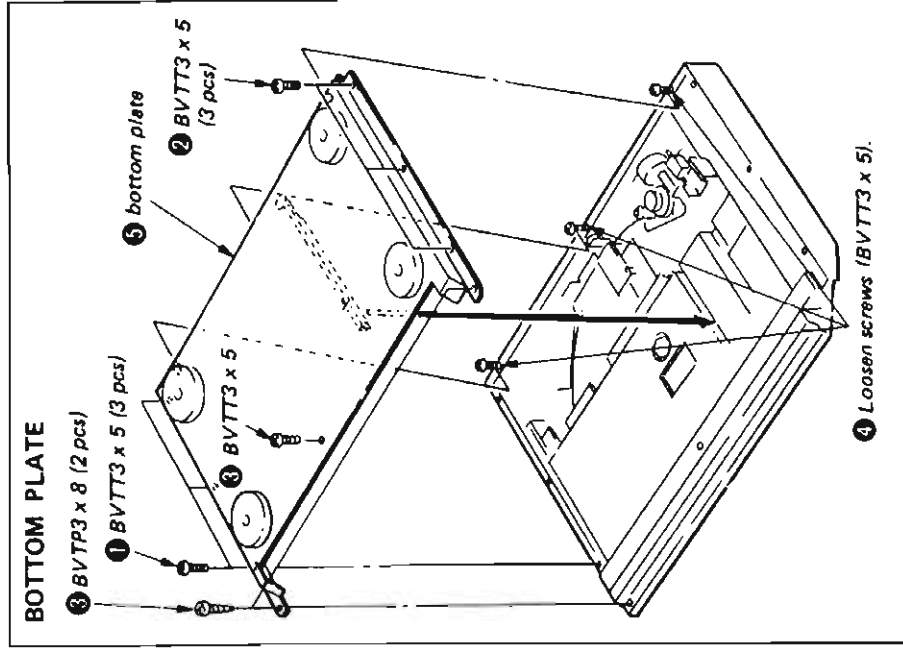

ARM DRIVE MOTOR (M702)

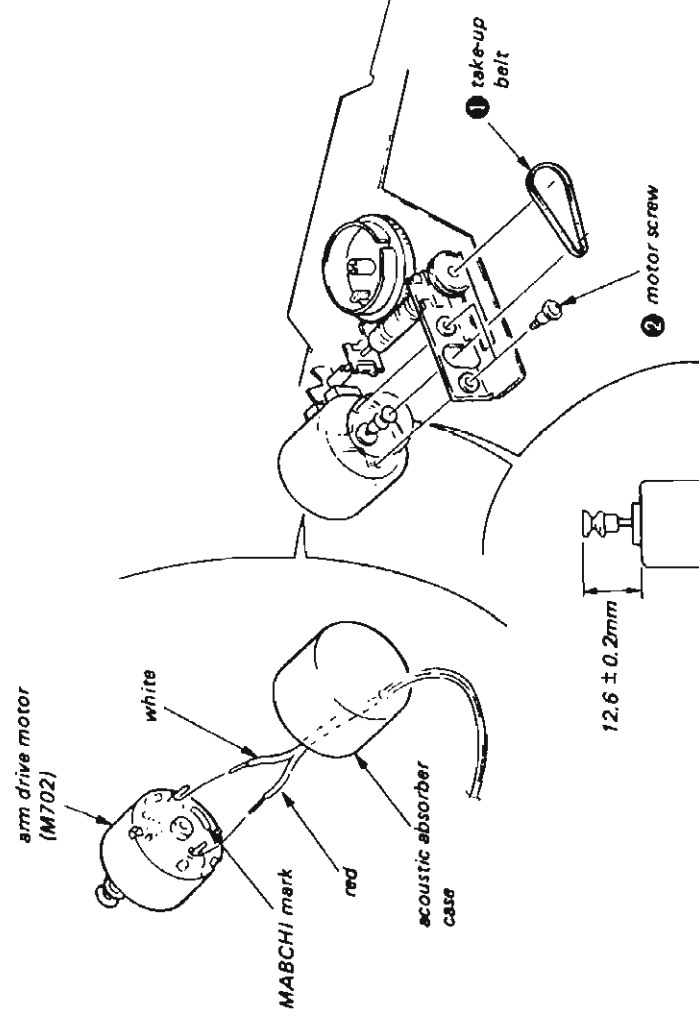

LOADING MOTOR (M701)

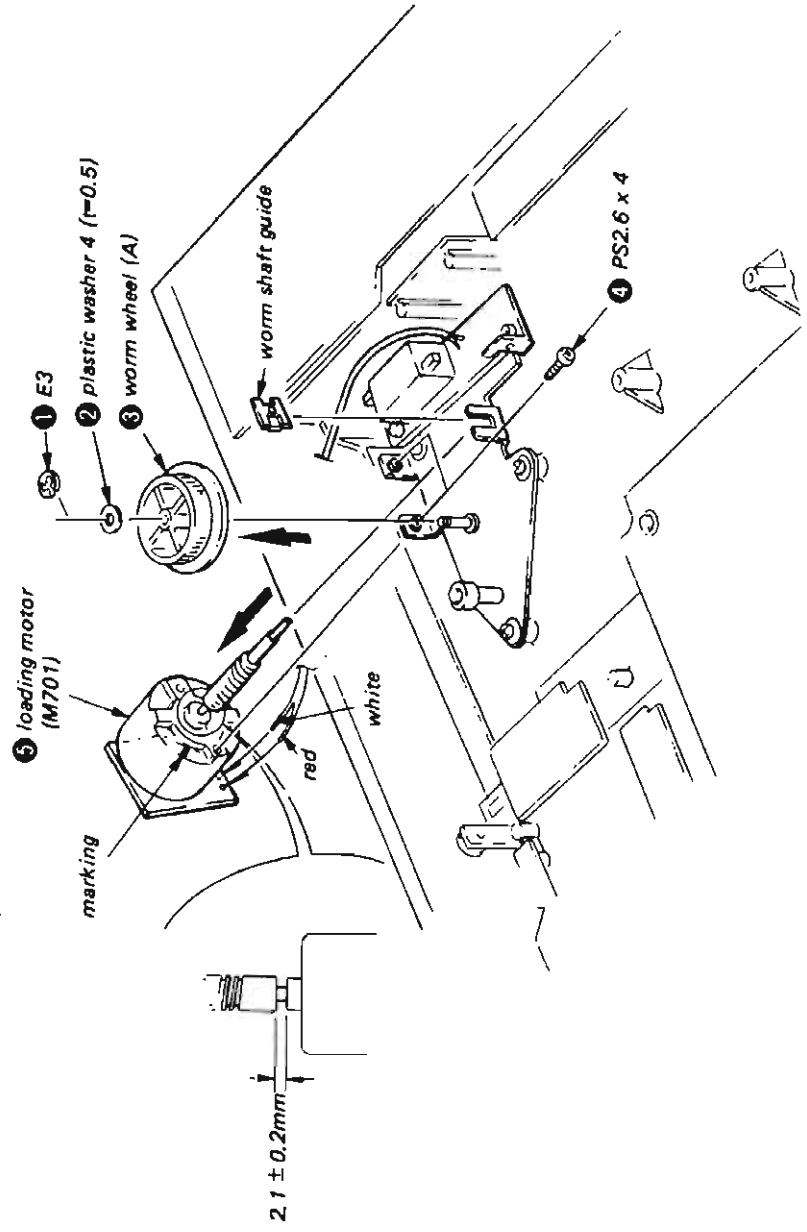

TONEARM DRIVE SECTION

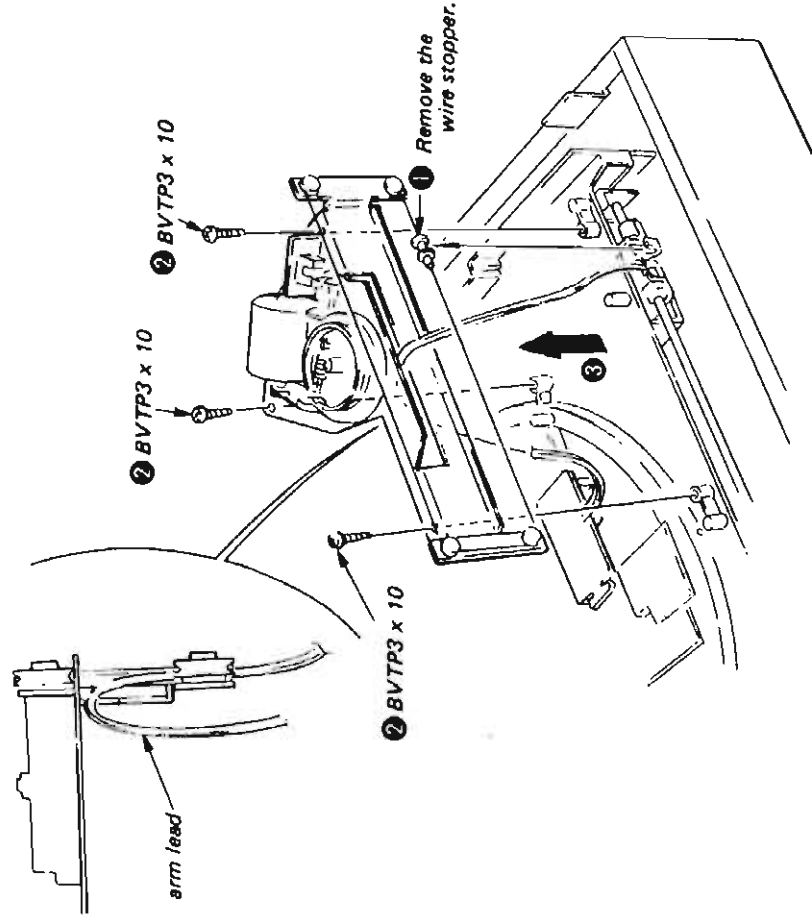

TONEARM DRIVE CORD
STRINGING (See page 23.)

REAR COVER

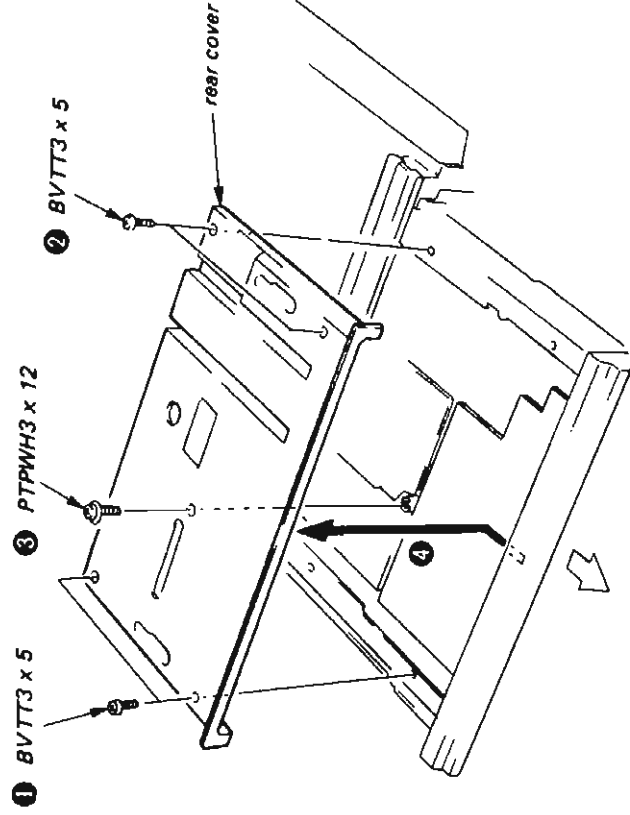

CONTROL PANEL/SYSTEM CONTROL BOARD

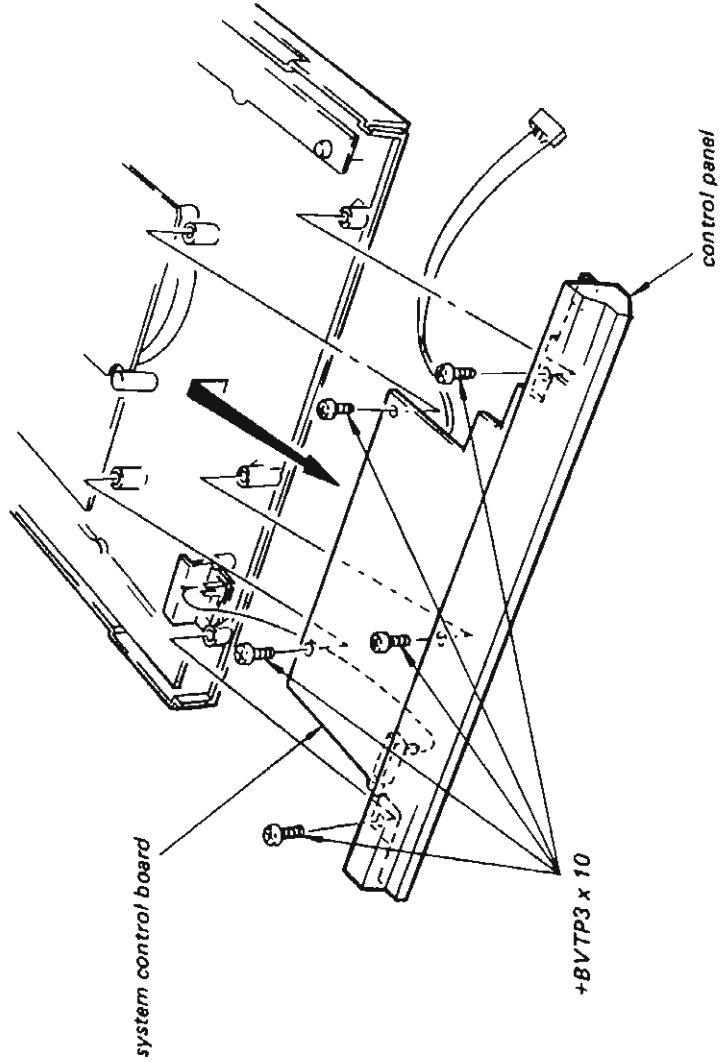

ROTOR/STATOR/FG BOARD/SERVO AMP BOARD

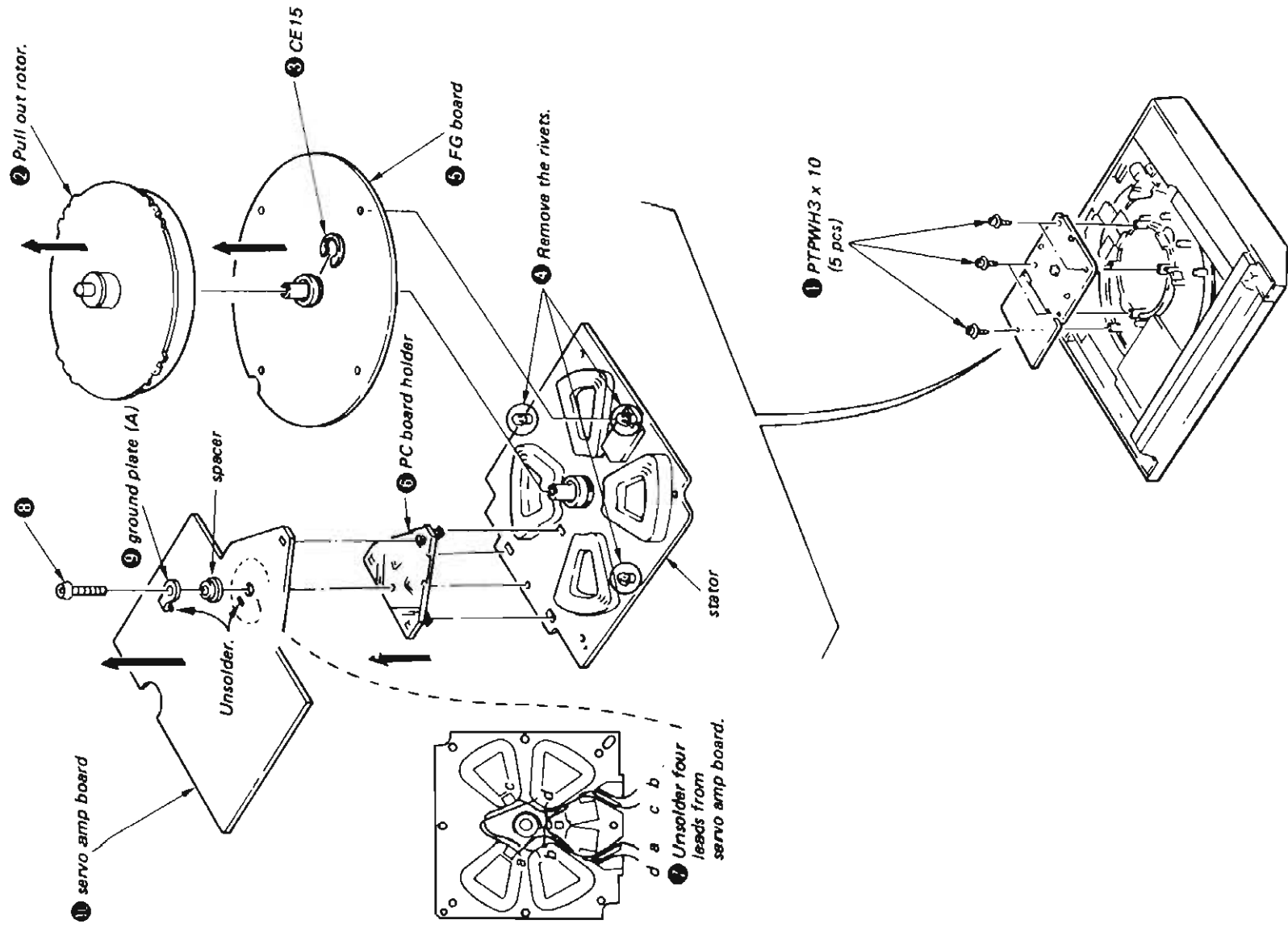

Remove the player case
(See page 15.).

TONEARM

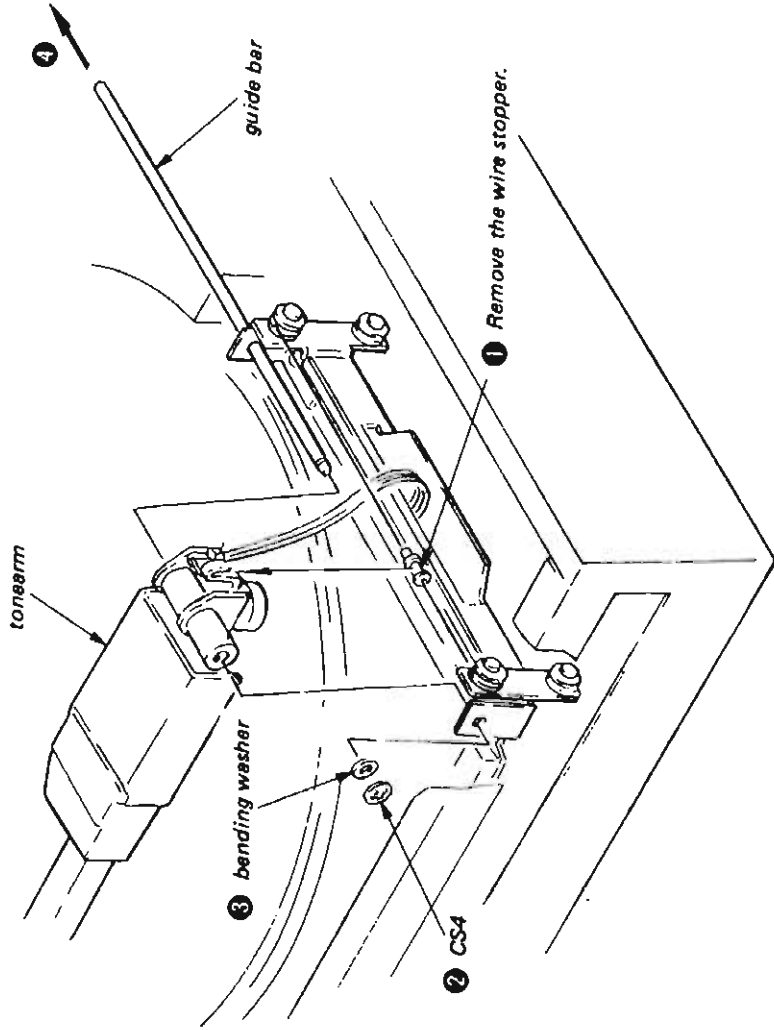

2.2. TONEARM ASSEMBLING

TONEARM ASSEMBLING (1)

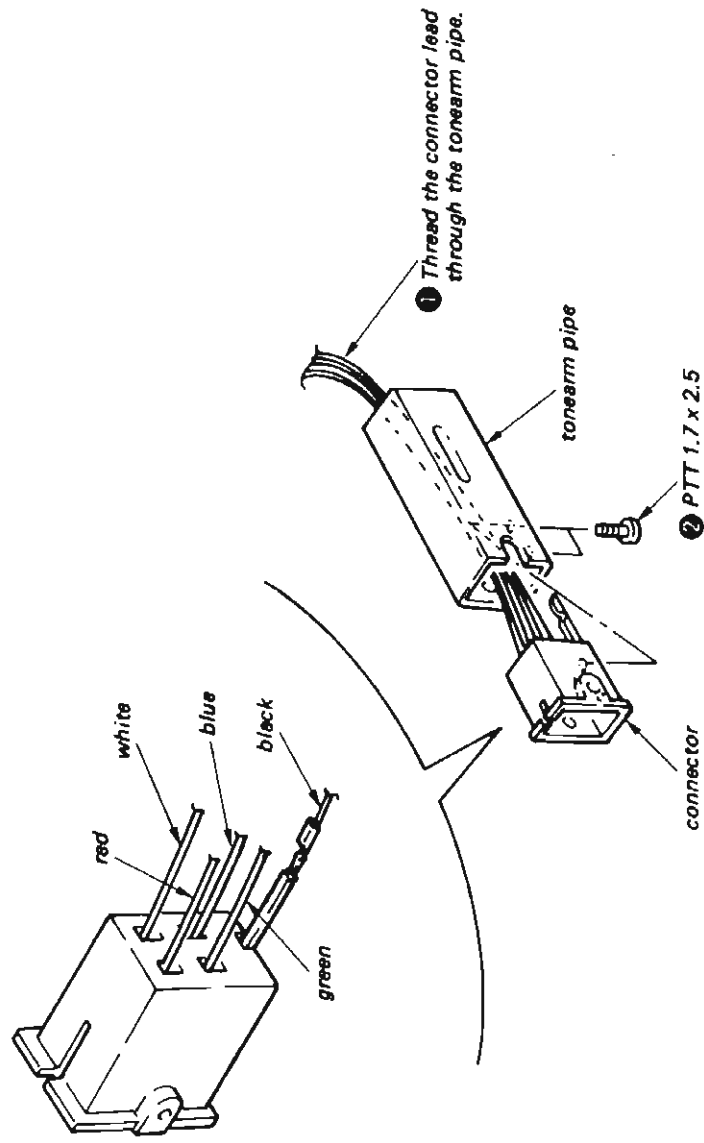

TONEARM ASSEMBLING (2)

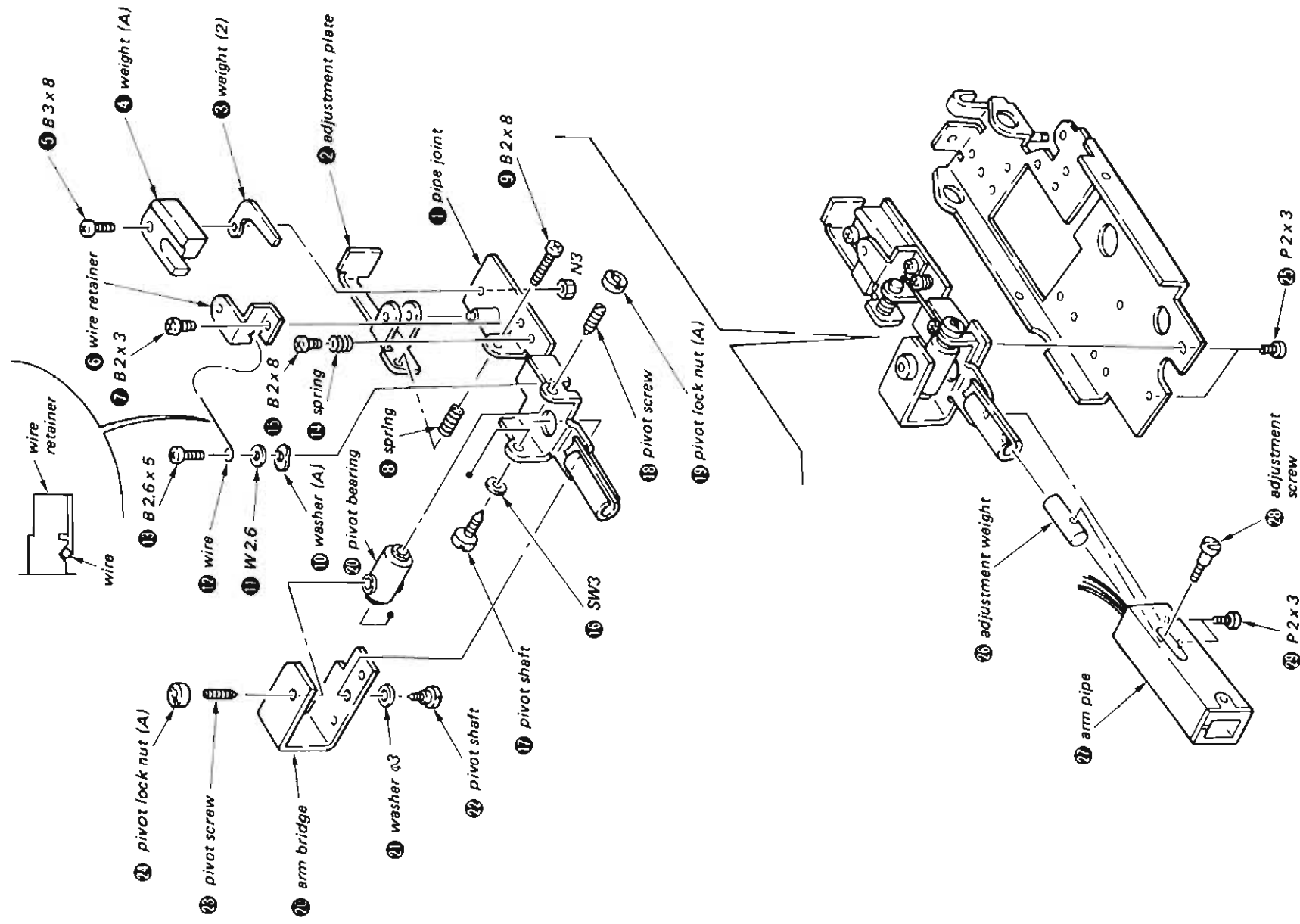

TONEARM ASSEMBLING (3)

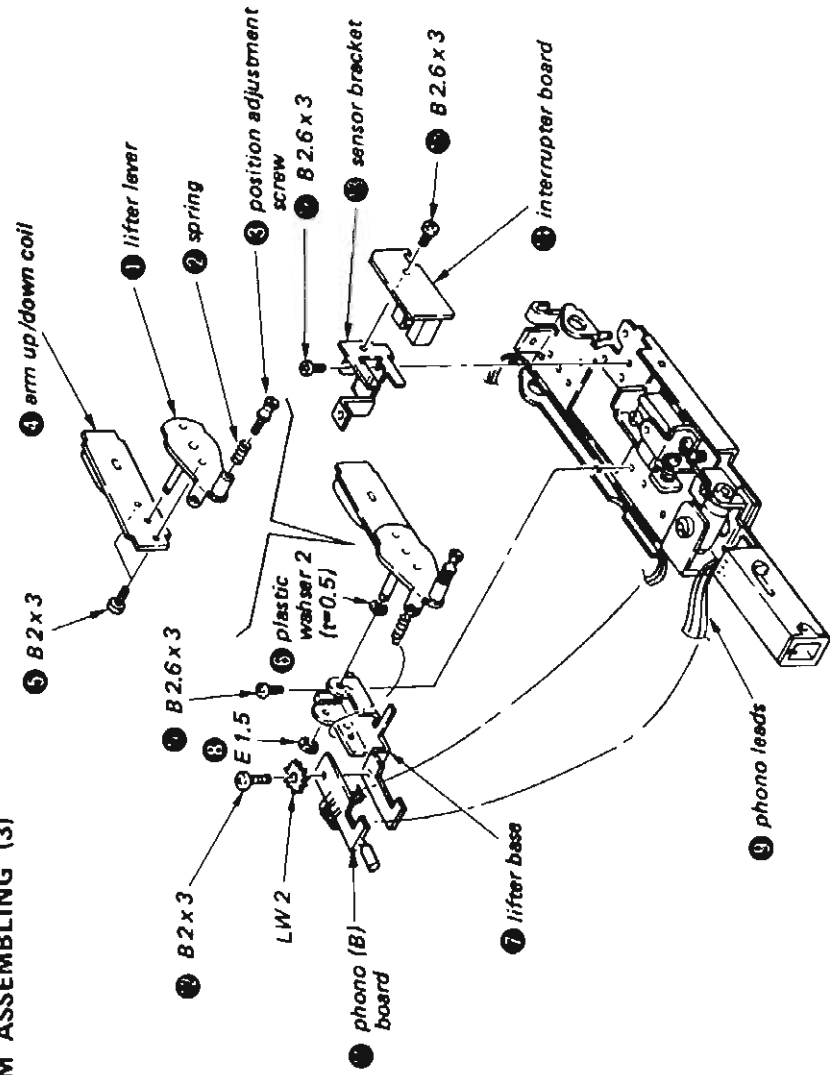

TONEARM ASSEMBLING (4)

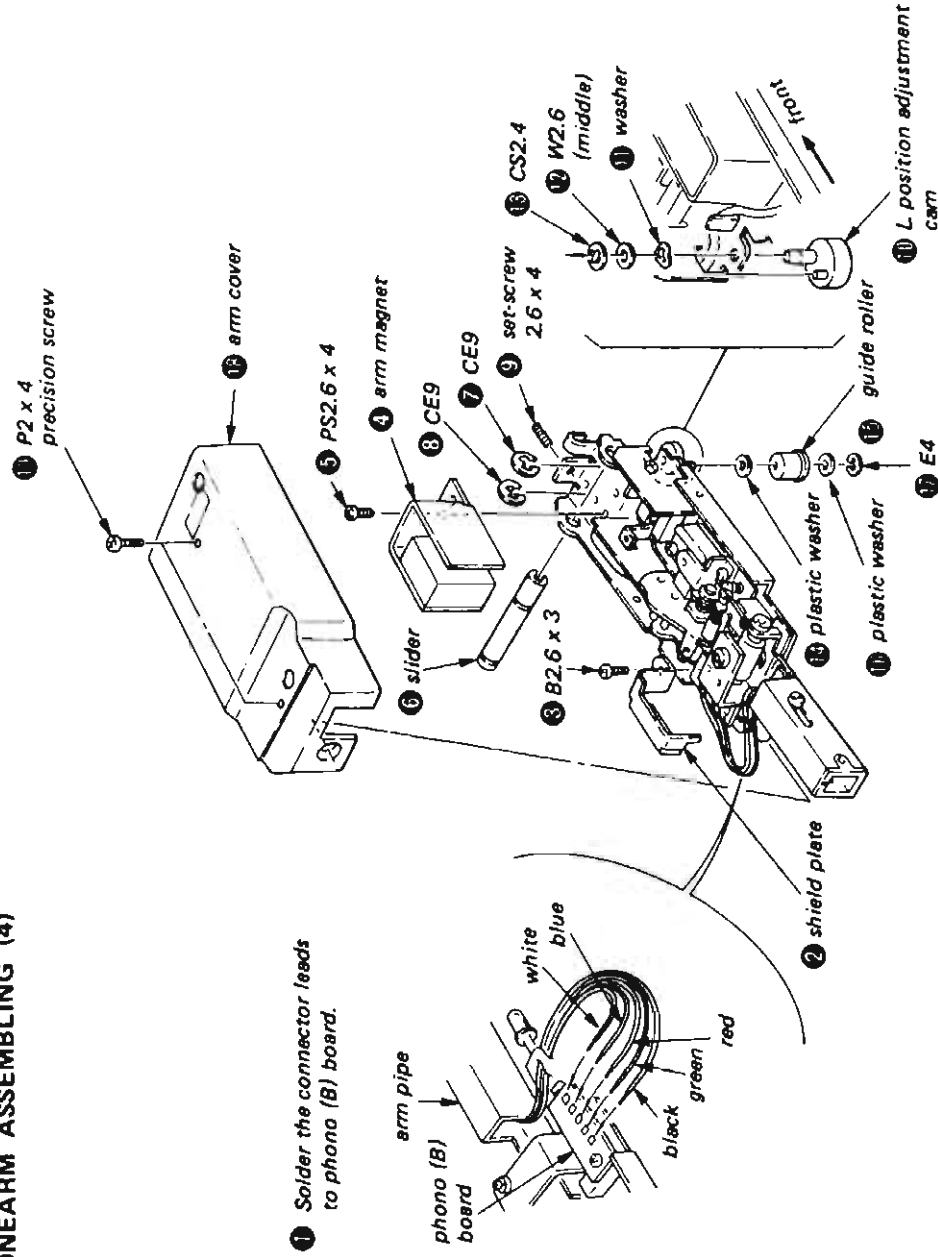

Remove the player case and bottom plate. (See page 15.)

POWER SUPPLY BOARD

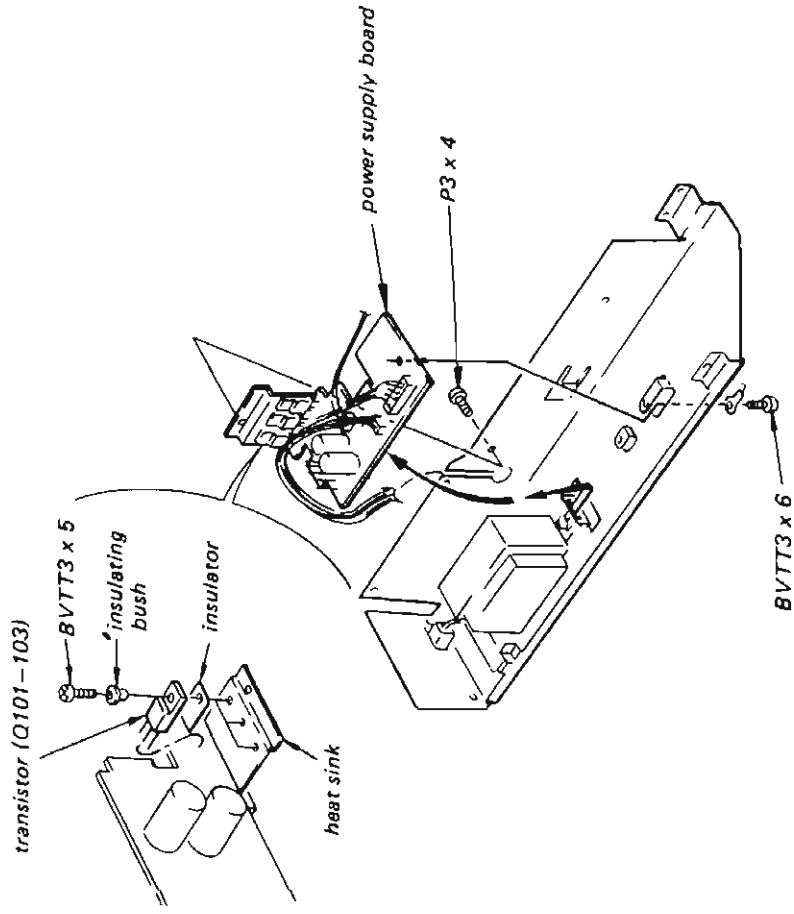
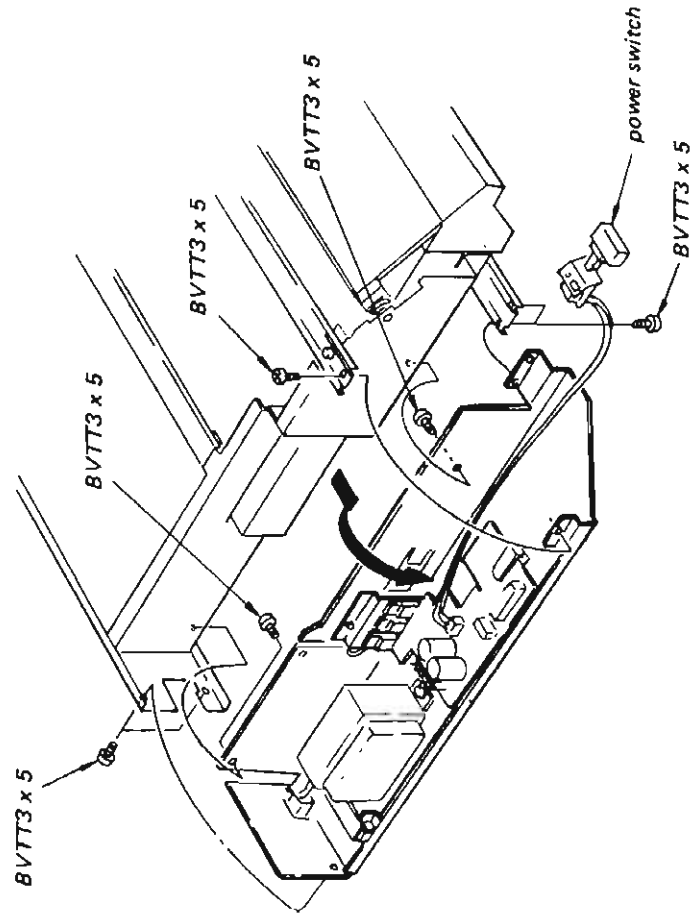

2.3. TONEARM DRIVE CORD STRINGING

(1) Preparation

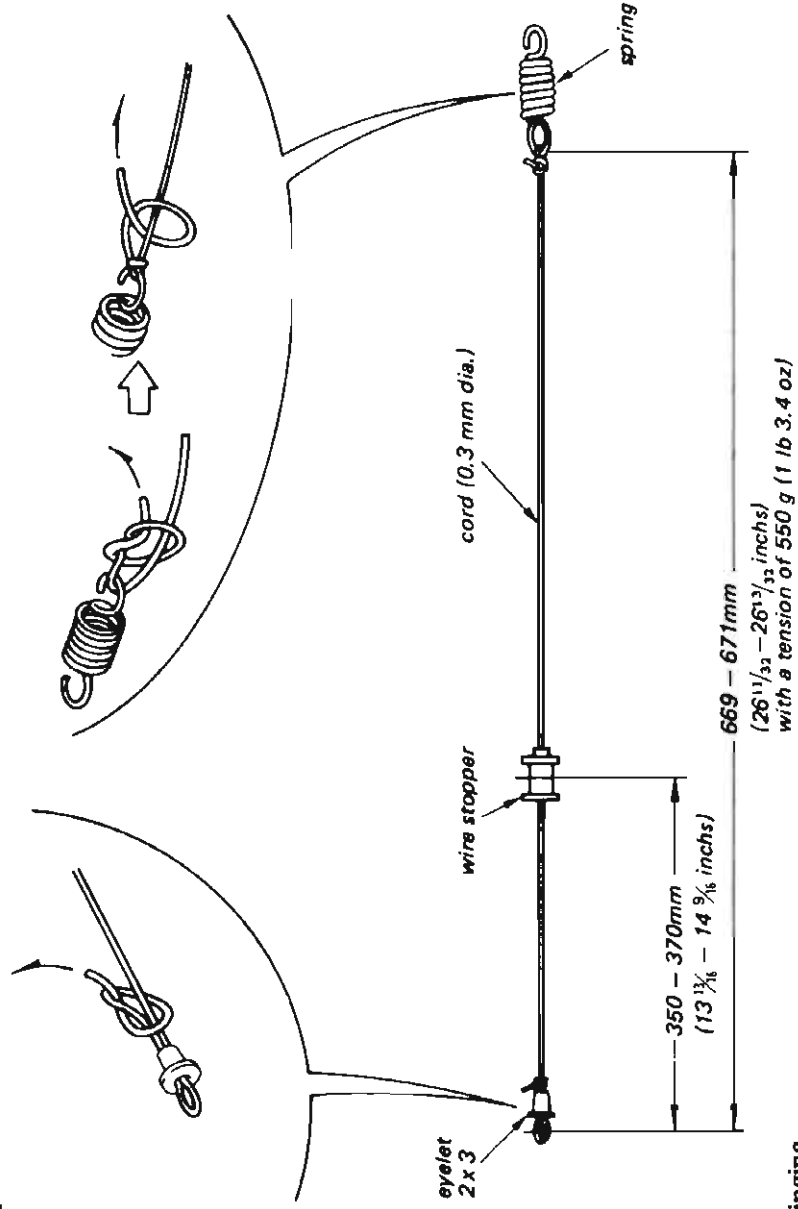

(2) Stringing

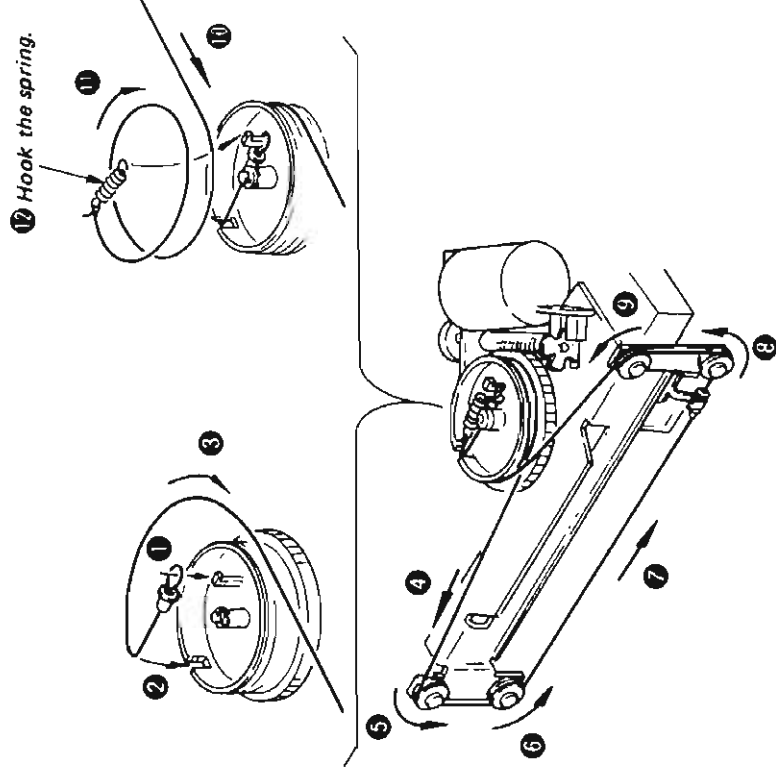

SECTION 3 ADJUSTMENTS

3-1. MECHANICAL ADJUSTMENTS

Stylus Height Adjustment

1. Put a record.
2. Press ARM TRANSPORT button (▲) and move the arm outside the record.
3. Make sure that clearance (A) is 4 - 8 mm ($\frac{3}{16}$ - $\frac{5}{16}$ inches). If necessary, adjust the stylus height adjustment screw.

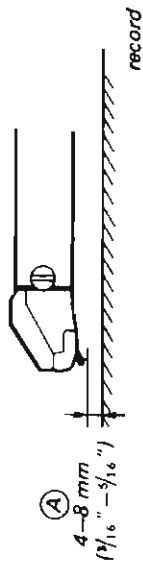

GENERAL NOTE:
Do not let a strong light get in the groove of photo interruptor during mechanical adjustment. Otherwise, misoperation of stoppage or moving may occur to the tonearm base.

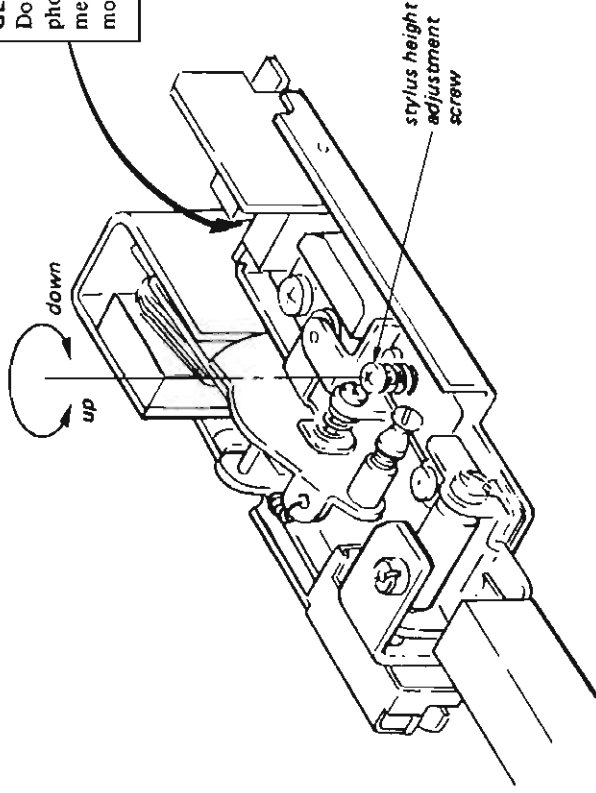

Lifter Height Adjustment

Adjust the lifter height adjustment screw so that the arm up/down coil position is 0 - 0.5 mm ($0'' - \frac{1}{32}''$) as shown below.

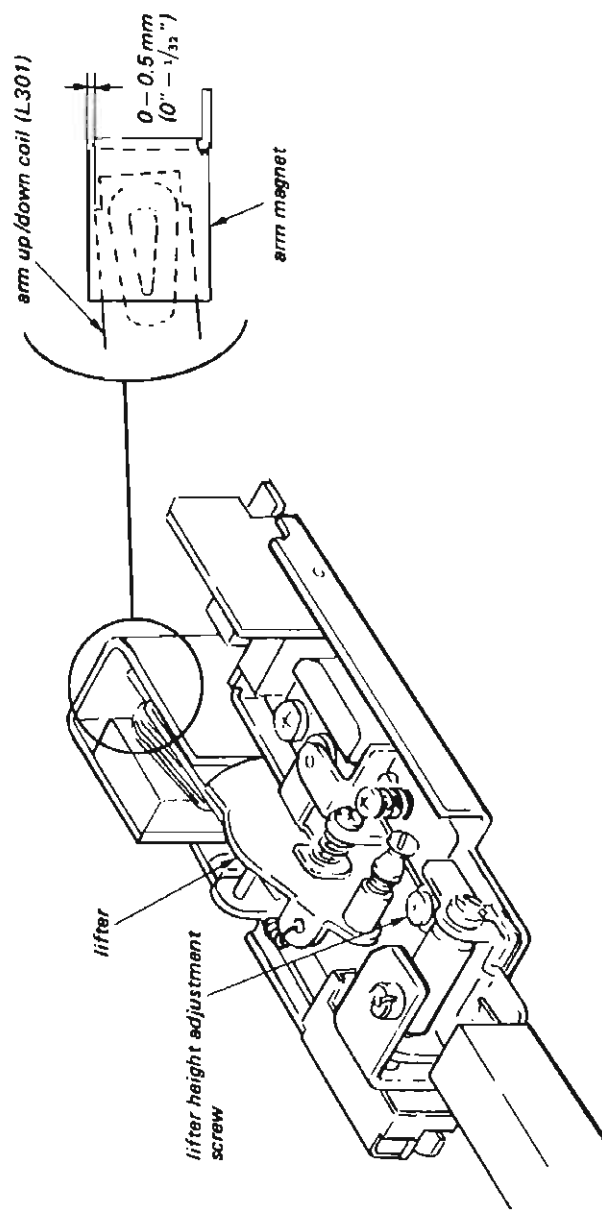

Tracking Error Adjustment

- (1) Place a test record (YFSC-16) on the turntable and press the START/STOP button for lead-in.
- (2) Adjust with the adjustment screw so that the tonearm base does not move just after the tonearm goes down.
- (3) After completing step (2), cause the tonearm to lead in, and then go UP after the tonearm base moves.
- (4) Check the count at this time, and then check that the difference in count when the tonearm goes down again is within 2 counts.

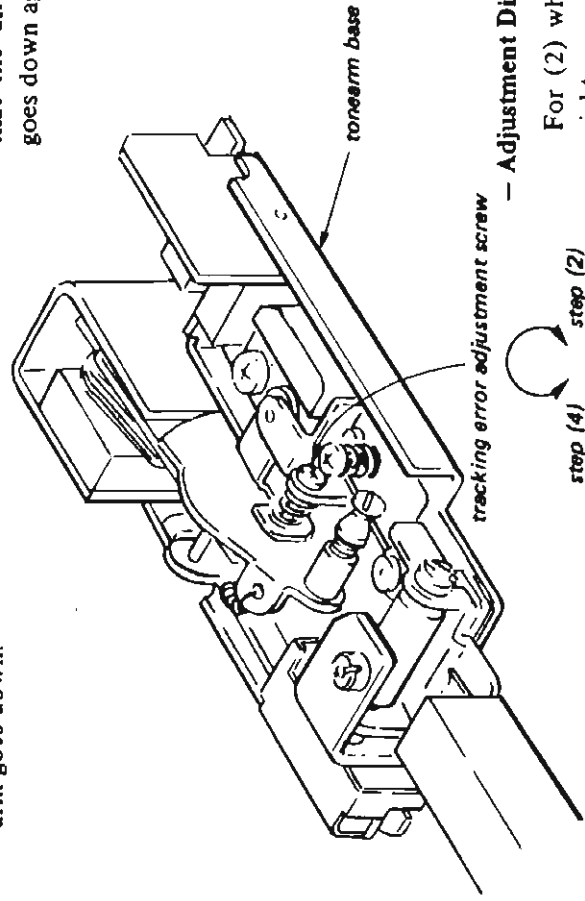

- Adjustment Direction -

For (2) when the arm base moves, turn to the right.

For (4) when the difference in count is too large, turn to the left.

Drop Point (30 cm) Adjustment

- (1) Place a test record (YFSC-16) on the turntable and press the START/STOP button for lead-in.
- (2) Adjust the horizontal position adjustment screw so that the drop point at this time is within the specification.

Specification: 8 - 14 counts

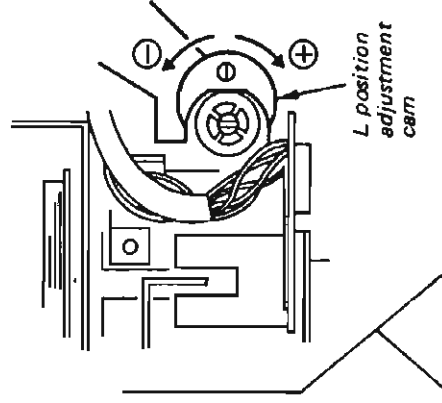
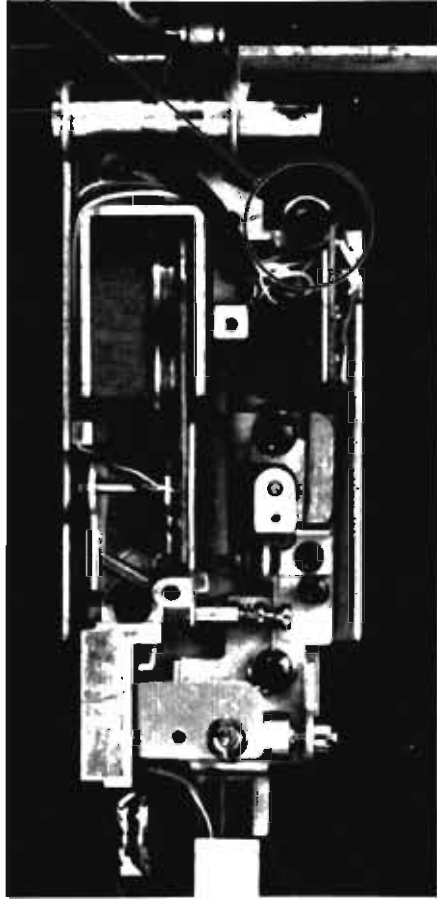

Arm Interrupter Adjustment

This adjustment should be performed only when replacing photo interrupter (PH301).

1. Press the arm transport button and move the arm over the turntable.
2. Press the arm lifter button and down the arm.
3. Set the arm fully rightward.
(Be sure that the interrupter for tracking error detection is fully opened.)
4. Read the voltage on the VOM.
If the reading is more than 0.6 V, solder the pattern **(A)**.

Adjustment Location:

—system control board —

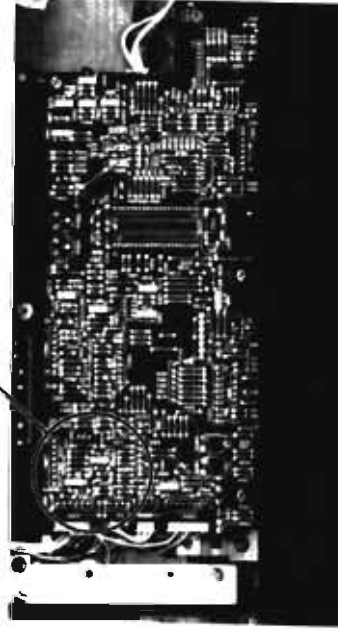
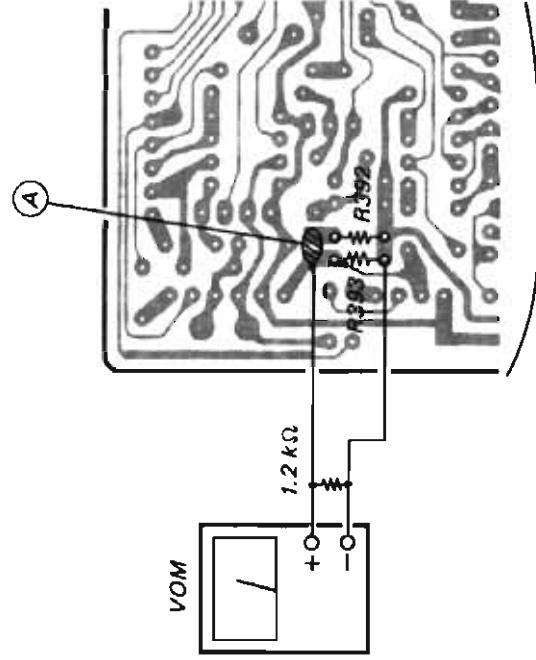

Blank Space Drop Point Adjustment

1. Set the RV301 (drop point adjustment resistor for user) to mechanical center.
2. Place the any one record on the turntable.
3. Press the OPEN/CLOSE button and close the turntable module.
4. Press the RMS button and play the second selection and last selection.
At this time, confirm that the stylus tip drops on the blank space.
If it is not, adjust RV302 and repeat steps 3 and 4.

Adjustment Location:

— system control board —

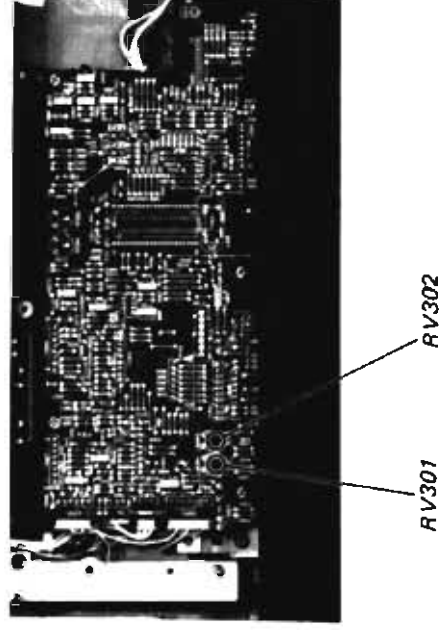

Gain Adjustment

1. Connect the pattern (A) to (B).
2. Apply a 0.5 V DC to the cathode of D205.
3. Adjust the RV201 (H701) and RV202 (H702) so that the terminal voltage of IC203 (1) (H701) and (9) (H702) are 5 Vp-p.
4. After adjustment, remove the lead wire connecting pattern (A) to (B).

— servo board —

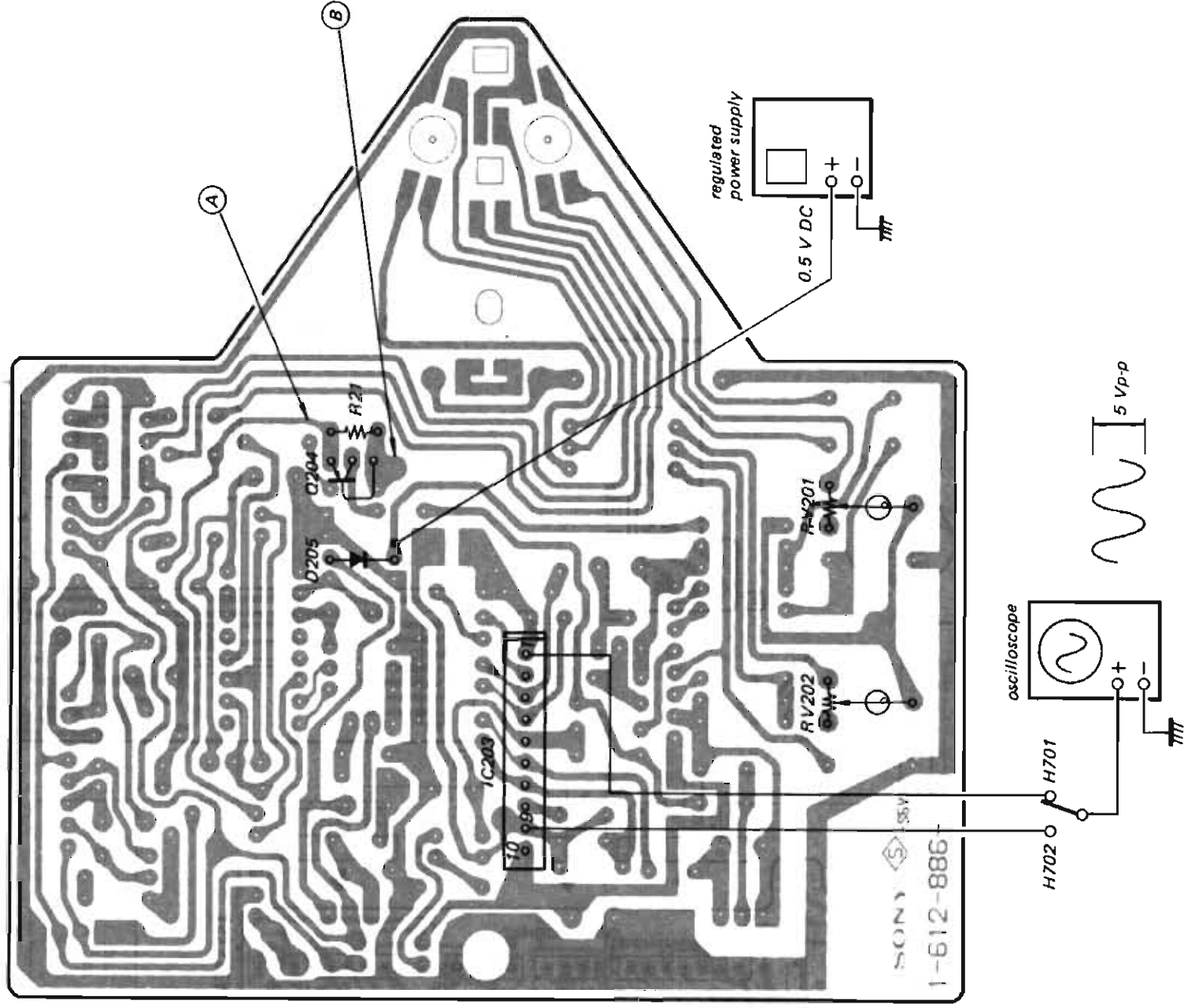

SECTION 4 DIAGRAMS

4-1. MOUNTING DIAGRAM

See page 38 for Semiconductor Lead Layouts.

Note:

Color code of sleeving over the end of the jacket.

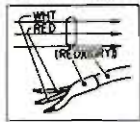

- : parts extracted from the component side.
- : parts extracted from the conductor side.
- : part mounted on the conductor side.

□ B + pattern
□ B - pattern

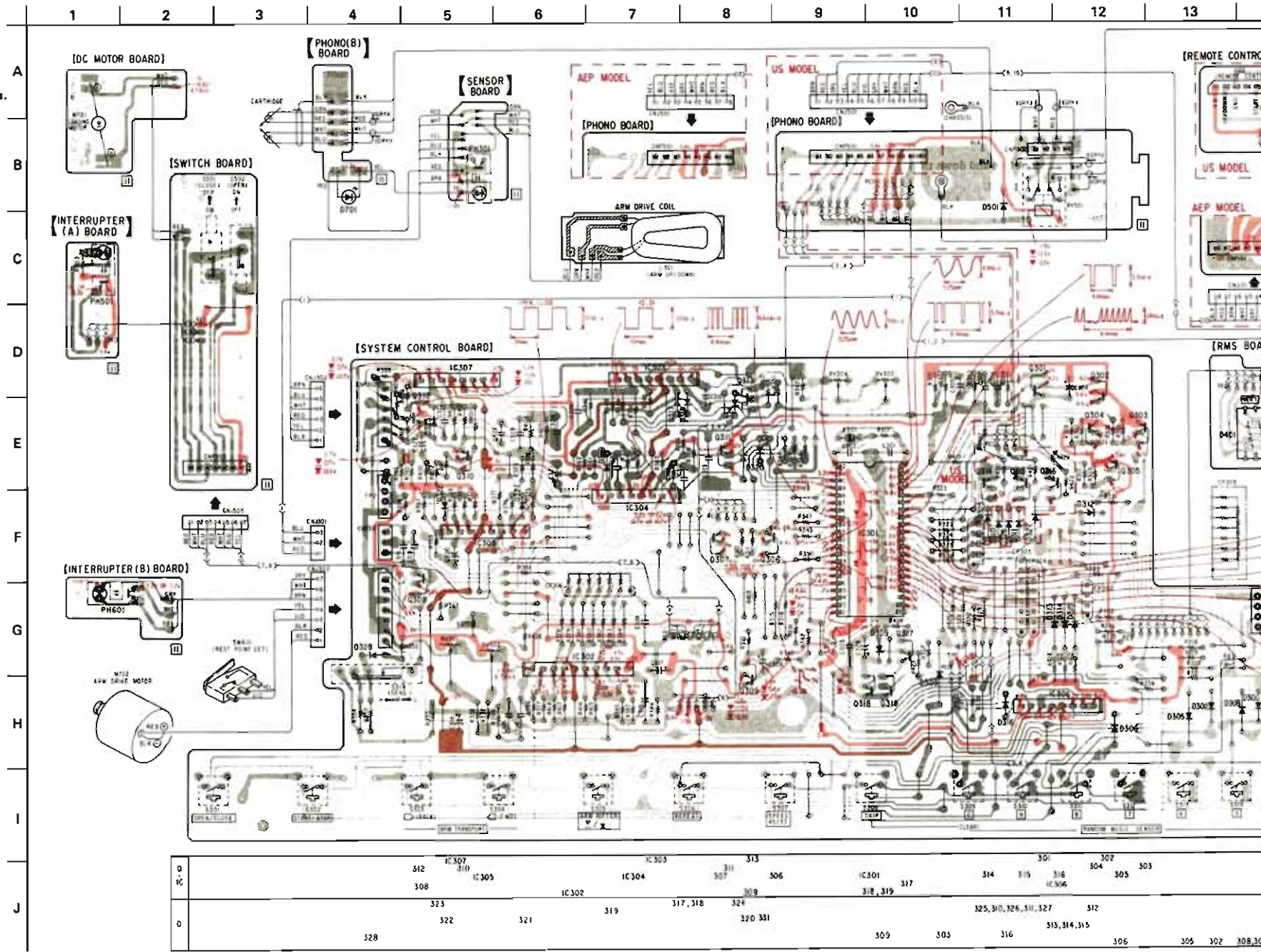

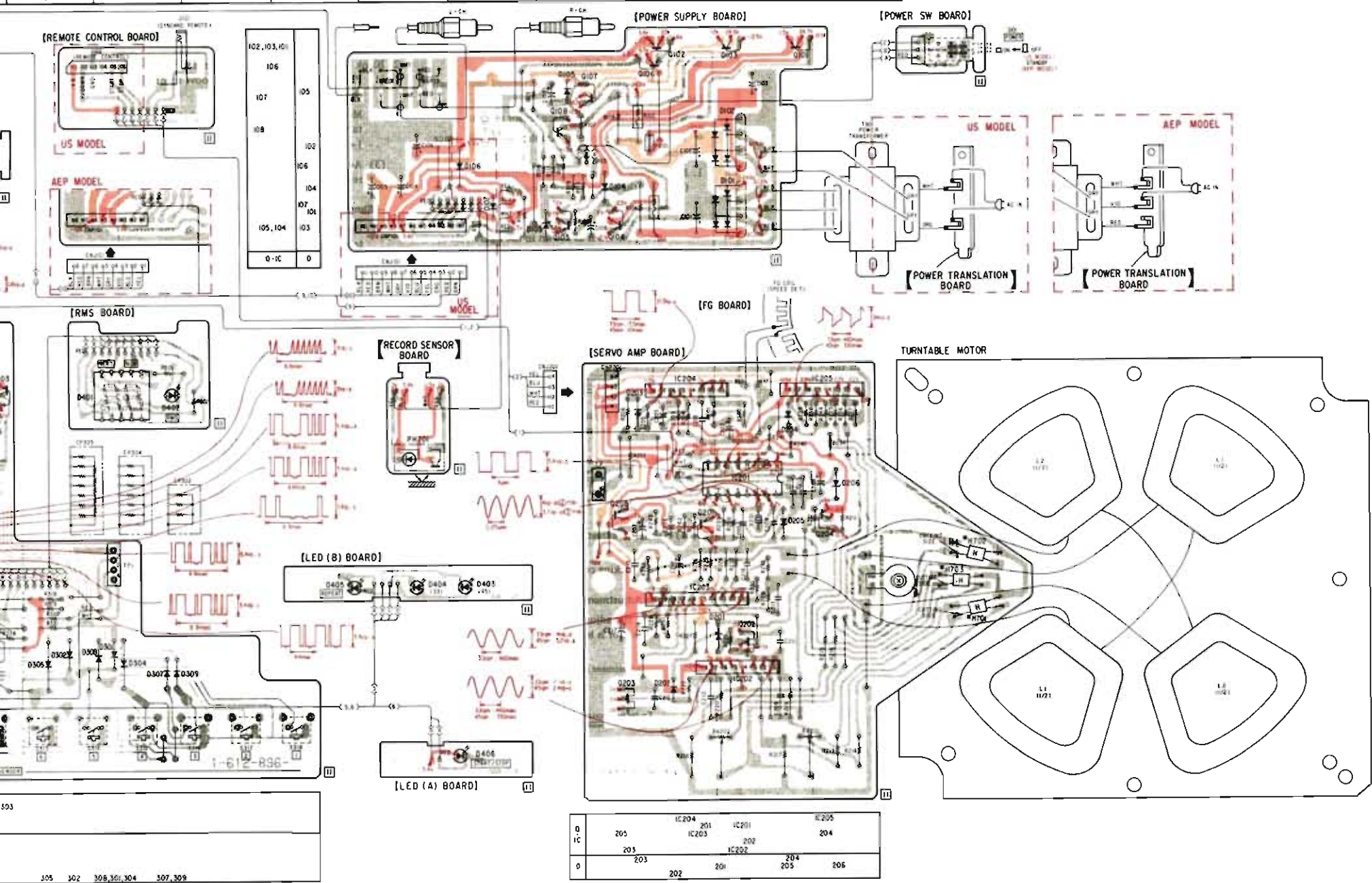

102, 103, 106	
106	105
107	
108	102
	106
	104
	107
	101
105, 104	103
0-IC	0

		IC204	201	IC201	IC205
0	IC	205	IC203	202	204
		203		IC202	
0		203	201	204	206
		202		205	

● Semiconductor Lead Layouts

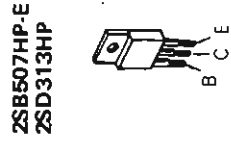
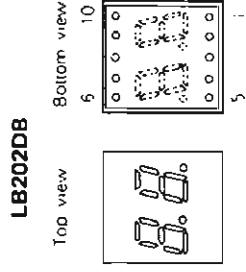
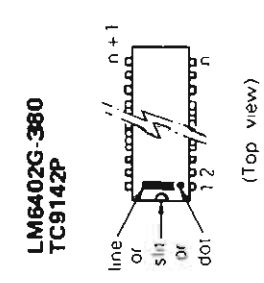

M5218L

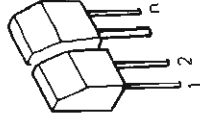

ZSA952

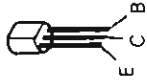

ZSD775-5



1SS119
1SS133
HZ7C2L
RD6.8J-N1

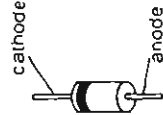

ZSA1175

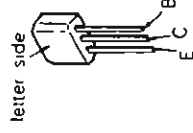

EAA5638S
EBG5638S
GL-5HY5

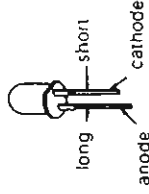

ZSC2458
DTA114ES
DTC114ES
DTC144ES



PG3531KY

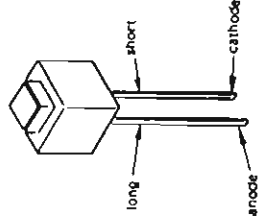

S1VB20

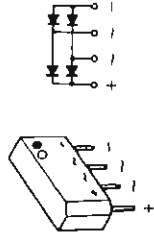

THS102A

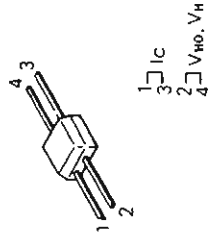

ZSK381-E

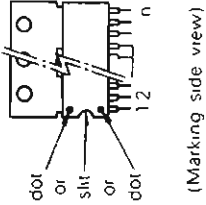

GP-1SD4



ON-1128

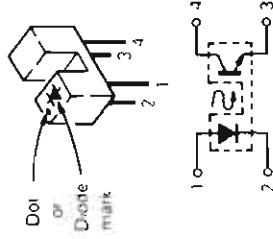

SECTION 5
EXPLODED VIEWS AND PARTS LIST

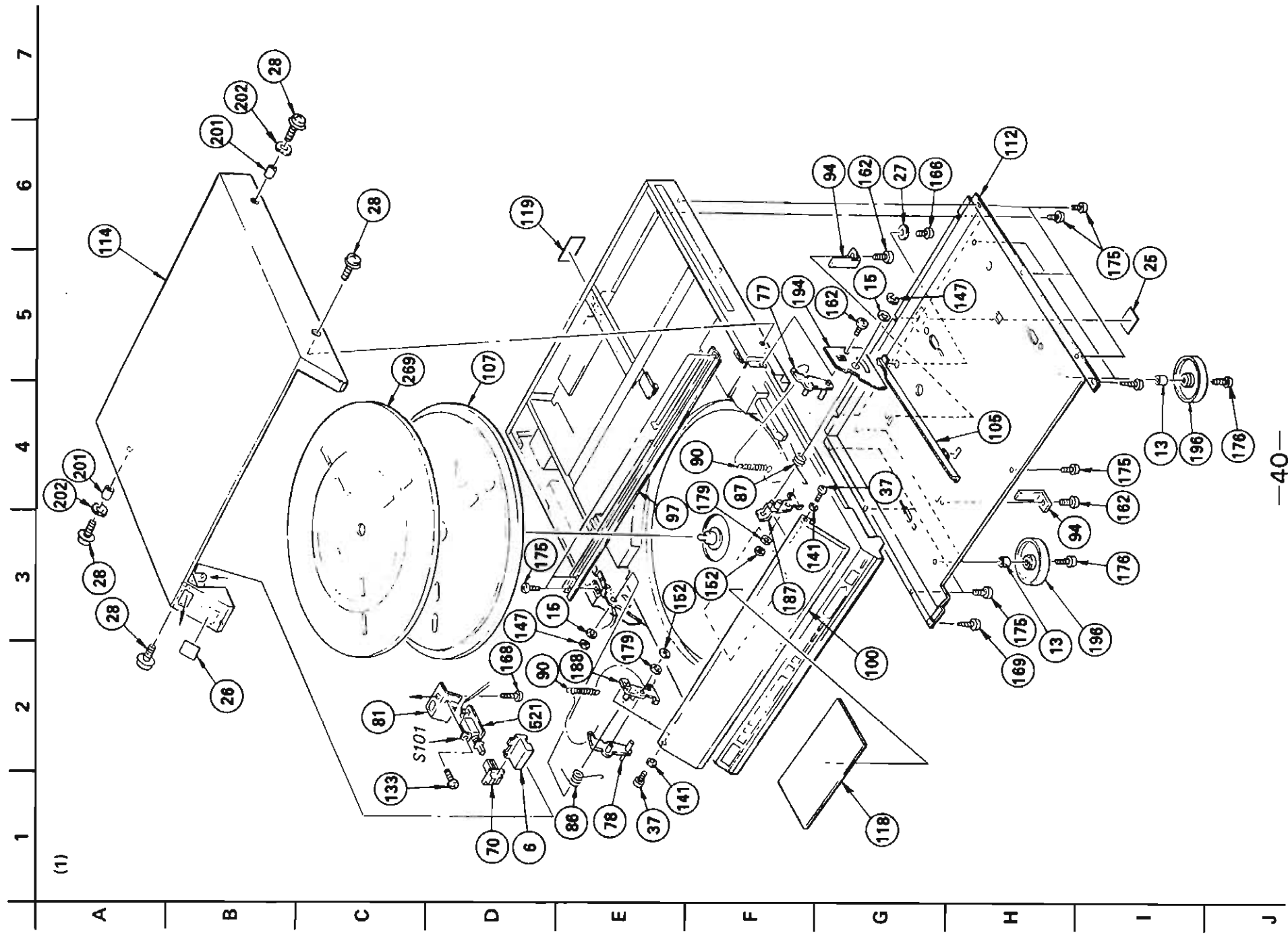

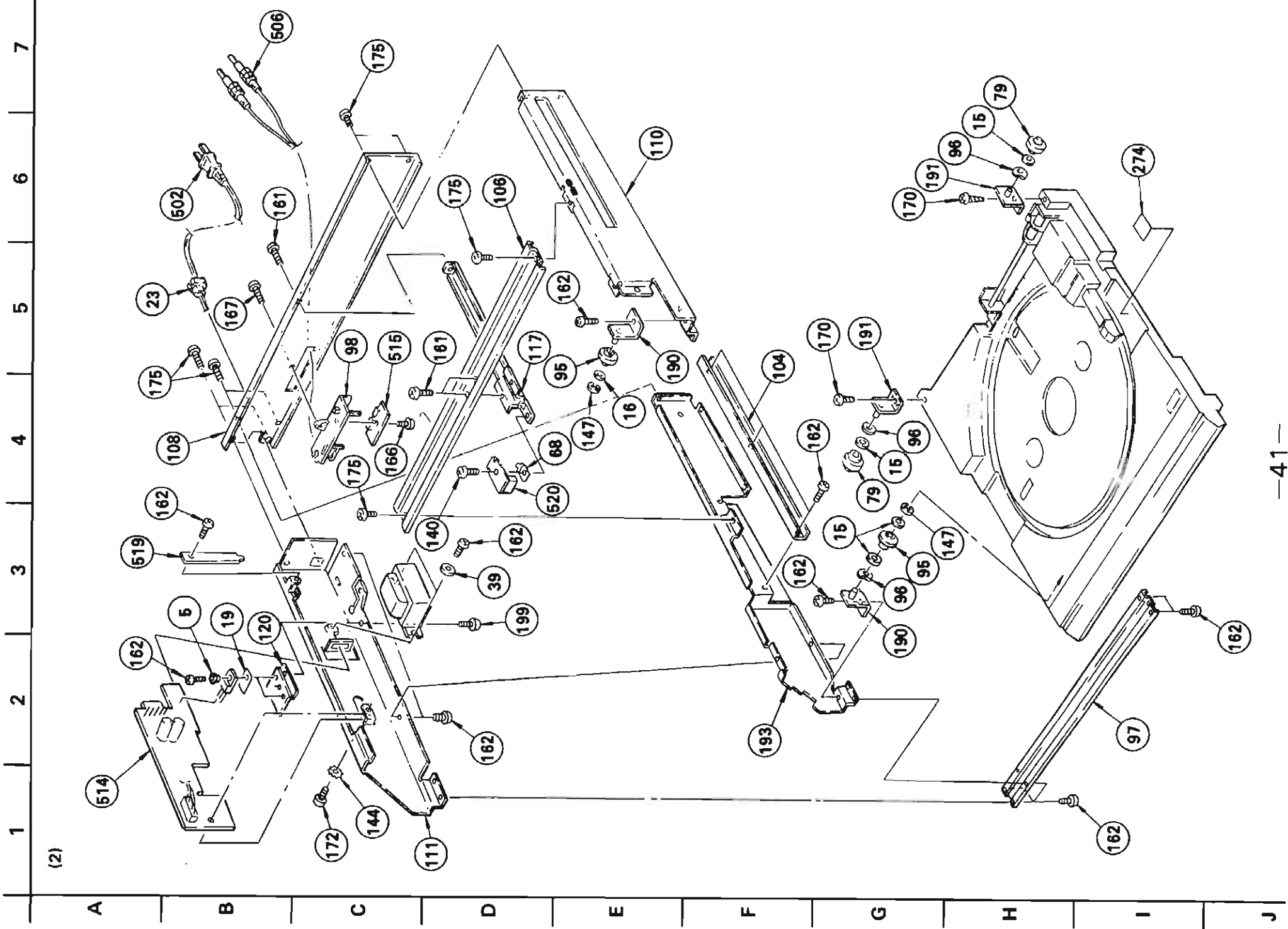

(4)

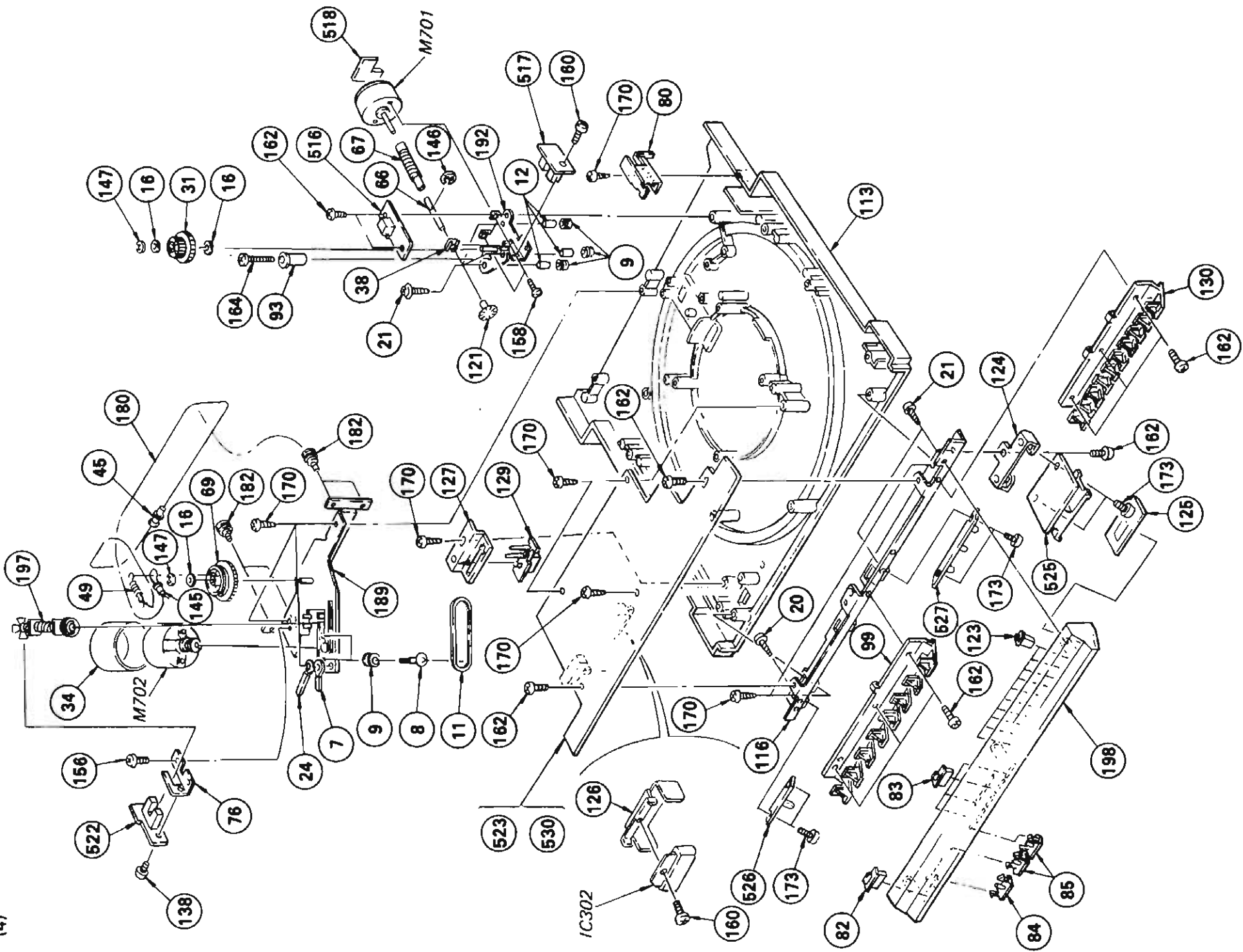

GENERAL SECTION

GENERAL SECTION

No.	Part No.	Description	No.	Part No.	Description
1	2-203-518-61	SCREW, PIVOT	44	4-885-737-00	WIRE
2	2-203-518-71	SCREW, PIVOT	45	4-885-744-00	STOPPER, WIRE
3	2-203-519-00	NUT (A), LOCK, PIVOT	46	4-885-746-00	SCREW, FITTING, CARTRIDGE
4	2-231-824-01	(AEP)...COVER, STYLUS	47	4-885-764-02	SPRING, COMPRESSION
5	2-371-561-00	BUSHING (P), INSULATING	48	4-885-766-00	SPRING, COMPRESSION
6	3-318-911-01	(SILVER)...KNOB (POWER.L), T MOLD	49	4-885-767-00	SPRING, TENSION
6	3-318-911-11	(BLACK)...KNOB (POWER.L), T MOLD	50	4-885-768-00	WEIGHT (2)
7	3-460-077-00	CLAMP, WIRE	51	4-885-770-00	WEIGHT, ADJUSTMENT
8	3-570-027-00	SCREW, MOTOR	52	4-885-771-00	SCREW, ADJUSTMENT
9	3-570-118-00	CUSHION, MOTOR	53	4-887-310-00	WEIGHT (A)
10	*****		54	*4-887-437-01	BASE, LIFTER
11	3-573-122-00	BELT, TAKE-UP	55	*4-887-438-01	PLATE, ADJUSTMENT
12	*3-654-058-00	SPACER 3X3	56	4-887-439-01	SPRING, TENSION
13	3-657-842-01	SPACER 3X4	57	4-887-439-01	SPRING, TENSION
14	3-701-437-21	WASHER, 2 (t=0.5)	58	*4-887-440-01	BRACKET, SENSOR
15	3-701-441-11	WASHER, 4 (t=0.25)	59	*4-887-444-01	RETAINER, WIRE
16	3-701-441-21	WASHER, 4 (t=0.5)	60	*4-887-446-01	PLATE, SHIELD
17	3-701-443-11	WASHER, 5 (t=0.25)	61	4-887-448-01	WASHER (A)
18	3-701-748-00	CLAMP	62	4-887-449-01	SHAFT, PIVOT
19	3-703-037-00	INSULATOR, TO-220	63	*4-887-451-01	SLIDER
20	3-703-136-00	SCREW, +PTPMH 3X12	64	4-887-454-11	BRIDGE, ARM
21	3-703-137-00	SCREW, +PTPMH 3X10	65	4-887-461-01	SPRING, COMPRESSION
22	3-703-150-11	CLAMP	66	4-888-902-00	SHAFT (A), WORM
23	3-703-244-00	(AEP)...BUSHING, CORD	67	4-888-904-00	WORM (A)
23	3-703-571-00	(US)...BUSHING (S), CORD	68	4-888-945-00	SPRING, LEAF
24	3-703-397-00	CLAMP	69	4-888-960-00	WHEEL, WORM
25	3-703-680-00	(US)...LABEL, CAUTION, SUB, NEW UL	70	*4-902-831-01	JOINT (G), KNOB
26	3-703-708-01	STICKER, SONY SYMBOL (18)	71	*4-903-330-01	NUT (TMD), BEARING
27	*4-301-647-00	WASHER, SPECIAL	72	4-903-347-01	(US)...COVER, STYLUS
28	4-820-330-51	(SILVER)...SCREW, RW, PLUS MINUS	73	4-904-236-00	SPRING
28	4-820-330-61	(BLACK)...SCREW, BW, PLUS MINUS	74	4-905-802-01	CAM, L POSITION ADJUSTMENT
29	4-857-642-00	HOLDER, PC BOARD	75	4-905-804-01	ROLLER, GUIDE
30	4-877-816-00	SHAFT, PIVOT	76	*4-905-805-01	BRACKET (B), SENSOR
31	4-879-514-00	WHEEL (A), WORM	77	4-905-806-01	LEVER (B,R), PANEL
32	*4-881-629-00	PLATE (A), GROUND	78	4-905-807-01	LEVER (B,L), PANEL
33	4-881-636-11	SUPPORT (TMD), PC	79	4-905-811-01	ROLLER (B), GUIDE
34	*4-882-233-00	CASE, ACOUSTIC ABSORBER	80	*4-905-813-01	PLATE
35	4-885-135-00	RETAINER, THRUST	81	*4-905-814-01	BRACKET, POWER SWITCH
36	*4-885-535-00	SUPPORT, TRANSPORT	82	4-905-820-11	KNOB (A)
37	4-885-599-00	SCREW, FITTING, REINFORCEMENT	83	4-905-820-01	(SILVER)...KNOB (A)
38	4-885-703-00	GUIDE, WORM SHAFT	83	4-905-820-21	(BLACK)...KNOB (A)
39	4-812-554-01	WASHR	84	4-905-821-01	(SILVER)...KNOB, SS
40	4-885-706-04	SCREW, ADJUSTMENT, POSITION	84	4-905-821-11	(BLACK)...KNOB, SS
41	4-885-724-00	BEARING	85	4-905-822-01	(SILVER)...KNOB, TRANSPORT
42	4-885-727-00	SPACER	85	4-905-822-11	(BLACK)...KNOB, TRANSPORT
43	4-885-728-00	PACKING			

NOTE:

- The mechanical parts with no reference number in the exploded views are not supplied.
- Items marked " * " are not stocked since they are seldom required for routine service. Some delay should be anticipated when ordering these items.

CAPACITORS:

- All capacitors are in μF . Common capacitors are omitted. Refer to the following lists for their part numbers.

MF: μF , Pf: μuF .

COILS

MH: mH, UH : μH

SEMICONDUCTORS

- In each case, U : μ , for example: UA...: μA ..., UPA...: μPA ..., UPC...: μPC , UPD...: μPD ...

GENERAL SECTION

GENERAL SECTION

No.	Part No.	Description	No.	Part No.	Description
86	4-905-824-01	SPRING, TORSION	124	*4-906-109-01	BRACKET, RMS PC BOARD
87	4-905-824-11	SPRING, TORSION	125	4-906-110-01	PLATE, FROSTED
88	*4-905-830-01	BRACKET (RIGHT), GUIDE BAR	126	*4-906-111-01	HEAT SINK (B)
89	*4-905-831-01	BRACKET (LEFT), GUIDE BAR	127	*4-906-112-01	BASE, KNOB
90	4-905-832-01	SPRING, TENSION	128	*4-906-113-01	LABEL, SENSITIVENESS SELECTION
91	4-905-834-01	PIPE, ARM	129	4-906-114-01	KNOB, SENSITIVENESS SELECTION
92	*4-905-835-01	BAR, GUIDE	130	4-906-115-01	KNOB (L), CONTROL
93	4-905-837-01	GUIDE, RACK	131	*4-906-116-01	HOLDER, LED
94	*4-905-838-01	PLATE, FUNCTION, LOADING SWITCH	132	7-621-735-09	SET-SCT,HEX. 2.6X4
95	4-905-841-01	ROLLER (A), GUIDE	133	7-621-759-35	+PSM, 2.6X5
96	4-905-842-01	WASHER, BENDING	134	7-621-772-00	SCREW +B 2X3
97	*4-905-843-01	REINFORCEMENT (LOWER)	135	7-621-772-08	SCREW +B 2X3
98	4-905-844-01	(US)...BOARD, TERMINAL, REMOTE CONTROL	136	7-621-772-30	SCREW +B 2X6
98	4-905-844-11	(AEP)...BOARD, TERMINAL, REMOTE CONTROL	137	7-621-772-40	SCREW +B 2X8
99	4-905-845-01	KNOB (R), CONTROL	138	7-621-775-00	SCREW +B 2.6X3
100	4-905-846-01	PANEL, FRONT	139	7-621-775-20	SCREW +B 2.6X5
101	*4-905-847-01	GUIDE (C)	140	7-621-775-40	SCREW +B 2.6X8
102	*4-905-848-01	COVER, ARM	141	7-623-207-22	SW 2.6, TYPE 2
103	*4-905-850-01	GUIDE (A)	142	7-623-208-22	SW 3, TYPE 2
104	*4-905-851-01	GUIDE (B)	143	7-623-420-07	LW 2, TYPE B
105	4-905-853-01	PLATE, RACK	144	7-623-422-07	LW 3, TYPE B
106	*4-905-854-01	REINFORCEMENT (UPPER)	145	7-623-616-01	EYELET, 2X3
107	4-905-855-01	TURNTABLE	146	7-624-102-04	STOP RING 1.5, TYPE -E
108	*4-905-856-01	PANEL, RACK	147	7-624-106-04	STOP RING 3.0, TYPE -E
109	*4-905-857-01	COVER, REAR	148	7-624-108-04	STOP RING 4.0, TYPE -E
110	*4-905-862-01	PLATE (R), SIDE	149	7-624-133-24	STOP RING 7, TYPE-CE
111	*4-905-863-01	PLATE (L), SIDE	150	7-624-133-44	STOP RING 9, TYPE-CE
112	*4-905-865-01	PLATE, BOTTOM	151	7-624-133-94	STOP RING 15, TYPE-CE
113	*4-905-866-01	FRAME	152	7-624-190-11	STOP RING 3, TYPE-CS
114	X-4905-815-1	(US:SILVER)...CASE, PLAYER	153	7-624-190-31	STOP RING 4, TYPE-CS
114	X-4905-817-1	(AEP:BLACK)...CASE, PLAYER	154	7-624-190-61	STOP RING 2.4, TYPE-CS
115	*4-905-873-01	PLATE, STOPPER	155	7-627-553-37	SCREW, PRECISION +P 2X3
116	*4-905-875-01	BRACKET, CONTROL PANEL	156	7-627-553-47	SCREW, PRECISION +P 2X4
117	*4-905-877-01	BRACKET, SENSOR	157	7-627-553-98	SCREW, PRECISION +P 2X8
118	4-905-879-11	(AEP)...LABEL, CAUTION	158	7-628-253-95	SCREW +PS 2.6X4
118	4-905-879-21	(US)...LABEL, CAUTION	159	7-682-149-13	SCREW +P 3X10
119	*4-906-101-01	(US)...LABEL, MODEL NUMBER (U,CND)	160	7-682-544-04	SCREW +B 3X3
119	*4-906-102-01	(G-AEP)...LABEL, MODEL NUMBER (AE 4)	161	7-682-545-04	SCREW +B 3X4
119	*4-906-103-01	(AEP)...LABEL, MODEL NUMBER (AE 1)	162	7-682-546-04	SCREW +BWT 3X5 (S)
120	*4-906-104-01	HEAT SINK (A)	163	7-682-548-09	SCREW +B 3X8
121	4-906-105-01	DISK, SLIT	164	7-682-553-04	SCREW +B 3X20
122	4-906-106-01	MARKER, STANDARD	165	7-684-023-04	N 3, TYPE 2
123	4-906-107-01	(SILVER)...KNOB, RMS	166	7-685-133-14	SCREW +P 2.6X6 TYPE2 SLIT
123	4-906-107-11	(BLACK)...KNOB, RMS	167	7-685-145-14	SCREW +BTP 3X6 TYPE2 N-S
			168	7-685-546-14	SCREW +BTP 3X8 TYPE2 N-S

NOTE:

The mechanical parts with no reference number in the exploded views are not supplied.

Items marked "★" are not stocked since they are seldom required for routine service. Some delay should be anticipated when ordering these items.

CAPACITORS:

All capacitors are in μF . Common capacitors are omitted. Refer to the following lists for their part numbers.

Mf: μF , Pf: μF .

COILS

MH : mH, UH : μH

SEMICONDUCTORS

In each case, U : μ , for example: UA...; LA...; UPA...; μPA ...

UPC...: μPC ,

UPD...: μPD ...

GENERAL SECTION

ACCESSORY & PACKING MATERIAL

No.	Part No.	Description	No.	Part No.	Description
169	7-685-646-19	SCREW +BVTP 3X8 TYPE2 N-S	251	3-565-234-00	BAG, PROTECTION
170	7-685-647-71	SCREW +BVTP 3X10 TYPE2 SLIT	252	3-610-931-11	SPACER, SHAFT, DRUM, HEAD
171	7-685-648-71	SCREW +BVTP 3X12	253	3-701-616-00	BAG, POLYETHYLENE
172	7-685-751-09	SCREW +BVTT 3X6 (S)	254	3-701-632-00	BAG, POLYETHYLENE
173	7-685-790-04	SCREW +BVTT 2.6X4 (S)	255	3-701-806-00	ADAPTOR, 45, (E)
174	7-685-799-04	SCREW +PTT 1.7X2.5	256	3-795-664-11	(AEP)...INSTRUCTION
175	7-685-870-09	SCREW +BVTT 3X5 (S)	257	3-795-753-21	(US)...INSTRUCTION
176	4-685-872-09	SCREW +BVTT 3X8	258	4-808-459-91	SCREW (B), MOTOR LOCK
177	7-688-002-01	M 2.6, SMALL	259	4-880-101-00	PLATE (B), PROTECTION
178	7-688-002-11	M 2.6, MIDDLE	260	4-885-746-00	SCREW, FITTING, CARTRIDGE
179	7-688-003-12	M 3, MIDDLE	261	4-888-942-00	SCREWDRIWER, ADJUSTMENT
180	9-911-825-32	STRING, TETRON DIAL (0.3MM)	262	4-905-825-01	PLATE (A), LOCK, TRANSPORT
181	A-4608-232-A	ROTOR ASSY	263	4-905-828-01	PLATE (B), LOCK, TRANSPORT
182	X-4856-325-0	PULLEY ASSY	264	4-905-868-01	CUSHION (LEFT)
183	*X-4887-409-1	LEVER ASSY, LIFTER	265	4-905-869-01	CUSHION (RIGHT)
184	X-4887-411-1	BEARING ASSY, PIVOT	266	4-905-876-01	SCREW, TRANSPORT
185	X-4887-413-1	STATOR ASSY	267	4-905-878-01	HOLDER, TURN TABLE
186	X-4887-415-1	MAGNET ASSY, ARM	268	4-905-881-01	PROTECTOR (SMALL)
187	*X-4905-801-1	LEVER (A,R) ASSY, PANEL	269	4-906-119-11	SHEET, TURNTABLE
188	*X-4905-802-1	LEVER (A,L) ASSY, PANEL	270	4-906-121-01	INDIVIDUAL CARTON
189	*X-4905-803-1	BRACKET ASSY, ARM MOTOR	271	3-773-929-11	(AEP)...MANUAL INSTRUCTION
190	*X-4905-804-1	BRACKET (A) ASSY, GUIDE ROLLER	272	3-773-929-21	(US)...MANUAL INSTRUCTION
191	*X-4905-805-1	BRACKET (B) ASSY, GUIDE ROLLER	273	4-905-880-11	LABEL, CAUTION
192	*X-4905-806-1	BRACKET ASSY, LOADING GEAR	274	*4-885-792-01	PLUG IN SEAL (A)
193	*X-4905-807-1	PLATE (C) ASSY, SIDE			
194	*X-4905-808-1	BRACKET (R) ASSY, PANEL LEVER			
195	*X-4905-809-1	BASE ASSY, ARM			
196	X-4905-813-1	INSULATOR ASSY			
197	X-4906-101-1	WORM ASSY			
198	X-4906-102-1	(SILVER)...CONTORL PANEL ASSY			
198	X-4906-103-1	(BLACK)...CONTORL PANEL ASSY			
199	7-682-145-01	SCREW +P 3X4			
200	X-4887-414-1	JOINT ASSY, PIPE			
201	4-905-886-01	COLLAR			
202	4-905-887-01	WASHER, WAVE			

NOTE:

- The mechanical parts with no reference number in the exploded views are not supplied.
- Items marked " * " are not stocked since they are seldom required for routine service. Some delay should be anticipated when ordering these items.

CAPACITORS:

- All capacitors are in μ F. Common capacitors are omitted. Refer to the following lists for their part numbers.
- MF: μ F, PF: μ uF.

COILS

- MMH : mH, UH : μ H

SEMICONDUCTORS

- In each case, U : μ , for example: UA...: LA...: UPA...: μ PA...:
- UPC...: μ PC,
- UPD...: μ PD...

ELECTRICAL PARTS

ELECTRICAL PARTS

Ref. No.	Part No.	Description	Ref. No.	Part No.	Description
501	*1-508-799-00	BASE POST (U TYPE)	C205	1-162-052-00	CERAMIC
502	*1-534-817-XX	(AEP)....CORD, POWER	C206	1-123-611-00	ELECT
502	*1-551-506-XX	(US)....CORD, POWER	C207	1-123-610-00	ELECT
503	*1-535-118-00	TERMINAL	C208	1-123-661-00	ELECT
504	1-549-117-00	(US)....CARTRIDGE (VL-45G)	C209	1-162-112-00	CERAMIC
505	1-549-118-11	(US)....STYLUS ASSY (ND-145G)	C210	1-162-112-00	CERAMIC
506	1-556-242-00	CORD, CONNECTION	C211	1-124-282-00	ELECT
507	1-556-552-00	CONNECTOR (PLUG IN TYPE)	C212	1-124-282-00	ELECT
508	*1-564-113-11	PIN, CONNECTOR 4P	C213	1-162-113-00	CERAMIC
509	*1-564-496-11	PIN, CONNECTOR 3P	C214	1-162-113-00	CERAMIC
510	*1-608-883-00	PC BOARD, FG	C215	1-162-113-00	CERAMIC
511	*1-612-356-11	PC BOARD, SENSOR	C216	1-162-113-00	CERAMIC
512	*1-612-721-11	PC BOARD, PHONO (B)	C217	1-123-821-00	ELECT
513	*1-612-886-11	PC BOARD, SERVO AMP	C218	1-123-821-00	ELECT
514	*1-612-887-11	PC BOARD, POWER SUPPLY	C219	1-162-113-00	CERAMIC
515	*1-612-888-11	PC BOARD, REMOTE CONTROL	C220	1-162-113-00	CERAMIC
516	*1-612-889-11	PC BOARD, SWITCH	C301	1-162-021-00	CERAMIC
517	*1-612-890-11	PC BOARD, INTERRUPTER (A)	C302	1-162-027-00	CERAMIC
518	*1-612-891-11	PC BOARD, DC MOTOR	C303	1-161-494-00	CERAMIC
519	*1-612-892-11	PC BOARD, POWER TRANSLATION	C304	1-123-661-00	ELECT
520	*1-612-893-11	PC BOARD, RECORD SENSOR	C305	1-123-611-00	ELECT
521	*1-612-894-11	PC BOARD, POWER SWITCH	C306	1-162-113-00	CERAMIC
522	*1-612-895-11	PC BOARD, INTERRUPTER (B)	C307	1-162-113-00	CERAMIC
523	*1-612-896-11	PC BOARD, SYSCON	C308	1-123-611-00	ELECT
524	*1-612-897-11	PC BOARD, PHONO	C309	1-161-380-00	CERAMIC
525	*1-612-898-11	PC BOARD, RMS	C310	1-123-820-00	ELECT
526	*1-612-899-11	PC BOARD, LED (A)	C311	1-162-110-00	CERAMIC
527	*1-612-900-11	PC BOARD, LED (B)	C312	1-162-110-00	CERAMIC
528	A-4505-089-C	(AEP)....CARTRIDGE (XL-250G)	C313	1-161-494-00	CERAMIC
529	A-4587-071-C	(AEP)....STYLUS ASSY (ND-250G)	C314	1-161-494-00	CERAMIC
530	*A-4616-016-A	(US)....MOUNTED PCB, SYSTEM CONTROL	C315	1-161-494-00	CERAMIC
530	*A-4616-017-A	(AEP)....MOUNTED PCB, SYSTEM CONTROL	C316	1-123-821-00	ELECT
531	*A-4619-245-A	MOUNTED PCB, SERVO	C317	1-123-821-00	ELECT
C101	*1-123-349-00	ELECT	C318	1-162-113-00	CERAMIC
C102	*1-123-349-00	ELECT	C319	1-162-113-00	CERAMIC
C103	1-123-324-00	ELECT	C320	1-123-610-00	ELECT
C104	1-123-821-00	ELECT	C321	1-123-644-00	ELECT
C105	1-123-821-00	ELECT	C322	1-162-113-00	CERAMIC
C106	1-123-661-00	ELECT	C323	1-124-282-00	ELECT
C107	1-123-620-00	ELECT	C324	1-162-113-00	CERAMIC
C108	1-123-620-00	ELECT	C325	1-162-113-00	CERAMIC
C201	1-161-494-00	CERAMIC	C326	1-162-113-00	CERAMIC
C202	1-123-821-00	ELECT	C327	1-123-617-00	ELECT
C203	1-123-616-00	ELECT	C328	1-162-113-00	CERAMIC
C204	1-162-052-00	CERAMIC	C329	1-123-612-00	ELECT

NOTE:

The mechanical parts with no reference number in the exploded views are not supplied.

Items marked " * " are not stocked since they are seldom required for routine service. Some delay should be anticipated when ordering these items.

CAPACITORS:

All capacitors are in μf . Common capacitors are omitted. Refer to the following lists for their part numbers.

Mf: μf , Pf: μpF .

COILS

MMH : mH, μH : μH

SEMICONDUCTORS

In each case, U : u, for example:

UA....: μA ..., UPA....: μPA ..., UPC....: μPC ,
UPD....: μPD ...

The components identified by shading and mark **A** are critical for safety. Replace only with part number specified.

ELECTRICAL PARTS

ELECTRICAL PARTS

Ref. No.	Part No.	Description	Ref. No.	Part No.	Description
CNP101*	1-560-608-00	(US)....PIN, CONNECTOR 11P	D321	8-719-901-33	DIODE 1SS133
CNP101*	1-560-709-00	(ACP)....PIN, CONNECTOR 8P	D322	8-719-901-33	DIODE 1SS133
			D323	8-719-901-33	DIODE 1SS133
CNP301*	1-564-112-21	PIN, CONNECTOR 3P	D324	8-719-901-33	DIODE 1SS133
CNP302*	1-564-115-00	PIN, CONNECTOR 6P	D325	8-719-911-19	(US)....DIODE 1SS119
CNP303*	1-564-116-00	PIN, CONNECTOR 7P	D326	8-719-911-19	(US)....DIODE 1SS119
CNP501*	1-564-117-11	(AFP)....PIN, CONNECTOR 8P	D327	8-719-911-19	(US)....DIODE 1SS119
CNP501*	1-564-120-11	(US)....PIN, CONNECTOR 11P	D328	8-719-901-33	DIODE 1SS133
CNP502*	1-564-113-11	PIN, CONNECTOR 4P	D329	8-719-901-33	DIODE 1SS133
CNP503*	1-564-501-11	PIN, CONNECTOR 8P	D331	8-719-901-33	DIODE 1SS133
CP302	1-232-529-00	COMPOSITION CIRCUIT BLOCK	D401	8-719-918-70	DIODE LB-20208
CP305	1-235-385-11	ENCAPSULATED COMPONENT	D402	8-719-914-51	DIODE PG3531KY
D101	△, 8-719-513-20	DIODE 51V820	D403	8-719-913-47	DIODE EAA5638S
D102	△, 8-719-513-20	DIODE 51V820	D404	8-719-913-47	DIODE EAA5638S
D103	8-719-103-36	DIODE RD5.8JMI	D405	8-719-913-47	DIODE EAA5638S
D104	8-719-901-33	DIODE 1SS133	D406	8-719-913-49	DIODE EBG5638S
D105	8-719-901-33	DIODE 1SS133	D501	8-719-901-33	DIODE 1SS133
D106	8-719-911-19	(US)....DIODE 1SS119	D701	8-719-900-57	DIODE GL-5HY5
D107	8-719-911-19	(US)....DIODE 1SS119	H701	8-719-800-17	DIODE THS102A
D201	8-719-901-33	DIODE 1SS133	H702	8-719-800-17	DIODE THS102A
D202	8-719-901-33	DIODE 1SS133	H703	8-719-800-17	DIODE THS102A
D203	8-719-901-33	DIODE 1SS133	IC201	8-759-201-58	IC TC9142P
D204	8-719-901-33	DIODE 1SS133	IC202	8-759-600-02	IC M5218L
D205	8-719-901-33	DIODE 1SS133	IC203	8-759-202-01	IC TA7256P
D206	8-719-910-78	DIODE HZ7G2L	IC204	8-759-600-02	IC M5218L
D301	8-719-901-33	DIODE 1SS133	IC205	8-759-600-02	IC M5218L
D302	8-719-901-33	DIODE 1SS133	IC301	8-759-801-02	IC LM6402G-380
D303	8-719-901-33	DIODE 1SS133	IC302	8-759-202-01	IC TA7256P
D304	8-719-901-33	DIODE 1SS133	IC303	8-759-600-02	IC M5218L
D305	8-719-901-33	DIODE 1SS133	IC304	8-759-600-02	IC M5218L
D306	8-719-901-33	DIODE 1SS133	IC305	8-759-600-02	IC M5218L
D307	8-719-901-33	DIODE 1SS133	IC306	8-759-600-02	IC M5218L
D308	8-719-901-33	DIODE 1SS133	IC307	8-759-600-02	IC M5218L
D309	8-719-901-33	DIODE 1SS133	J101	1-507-813-00	JACK (SYNCHRONIZED OPERATION)
D310	8-719-901-33	DIODE 1SS133	J102	*1-560-317-00	(US)....CONNECTOR PIN 6P (REMOTE CONTROL)
D311	8-719-901-33	DIODE 1SS133	L301	1-422-162-11	COIL, ARM UP/DOWN
D312	8-719-901-33	DIODE 1SS133	L302	1-407-169-XX	MICRO INDUCTOR 100UH
D313	8-719-901-33	DIODE 1SS133	M701	1-541-163-00	MOTOR (LOADING MOTOR)
D314	8-719-901-33	DIODE 1SS133	M702	A-4608-231-A	MOTOR ASSY (ARM MOTOR)
D315	8-719-901-33	DIODE 1SS133	PH301	8-719-411-28	DIODE OM1128
D316	8-719-901-33	DIODE 1SS133	PH501	8-719-918-74	DIODE GP-1S04
D317	8-719-901-33	DIODE 1SS133	PH601	8-719-918-74	DIODE GP-1S04
D318	8-719-901-33	DIODE 1SS133	PH701	1-806-664-11	PHOTO COUPLER (REFLECTION TYPE)
D319	8-719-901-33	DIODE 1SS133	PS101	△ 1-532-605-00	LINK, IC
D320	8-719-901-33	DIODE 1SS133			

NOTE:

The mechanical parts with no reference number in the exploded views are not supplied.

Items marked " * " are not stocked since they are seldom required for routine service. Some delay should be anticipated when ordering these items.

CAPACITORS:

All capacitors are in μ F. Common capacitors are omitted. Refer to the following lists for their part numbers.

Mf: μ F, P: puf.

COILS

MWH : mH, UH : μ H

SEMICONDUCTORS

In each case, U : μ , for example:

UA...: μ A..., UPA...: μ PA..., UPC...: μ PC, UPD...: μ PD...

The components identified by shading and mark Δ are critical for safety. Replace only with part number specified.

ELECTRICAL PARTS

ELECTRICAL PARTS

Ref.No.	Part No.	Description
Q101	8-729-831-33	TRANSISTOR 2SD313HP
Q102	8-729-831-33	TRANSISTOR 2SD313HP
Q103	8-729-850-73	TRANSISTOR 2SB507HP-E
Q104	8-729-245-83	TRANSISTOR 2SC2458
Q105	8-729-245-83	TRANSISTOR 2SC2458
Q106	8-729-245-83	TRANSISTOR 2SC2458
Q107	8-729-117-54	TRANSISTOR 2SA1175
Q108	8-729-117-54	TRANSISTOR 2SA1175
Q201	8-729-245-83	TRANSISTOR 2SC2458
Q202	8-729-600-08	TRANSISTOR 2SK381-E
Q203	8-729-600-08	TRANSISTOR 2SK381-E
Q204	8-729-117-54	TRANSISTOR 2SA1175
Q205	8-729-245-83	TRANSISTOR 2SC2458
Q301	8-729-245-83	TRANSISTOR 2SC2458
Q302	8-729-245-83	TRANSISTOR 2SC2458
Q303	8-729-195-23	TRANSISTOR 2SA952
Q304	8-729-195-23	TRANSISTOR 2SA952
Q305	8-729-195-23	TRANSISTOR 2SA952
Q306	8-729-900-89	TRANSISTOR DTC144ES
Q307	8-729-900-89	TRANSISTOR DTC144ES
Q308	8-729-900-89	TRANSISTOR DTC144ES
Q309	8-729-900-80	TRANSISTOR DTC114ES
Q310	8-729-900-80	TRANSISTOR DTC114ES
Q311	8-729-900-61	TRANSISTOR DTA114ES
Q312	8-729-177-44	TRANSISTOR 2SD774-5
Q313	8-729-600-08	TRANSISTOR 2SK381-E
Q314	8-729-900-89	(US)...TRANSISTOR DTC144ES
Q315	8-729-900-89	(US)...TRANSISTOR DTC144ES
Q316	8-729-900-89	(US)...TRANSISTOR DTC144ES
Q317	8-729-245-83	TRANSISTOR 2SC2458
Q318	8-729-900-80	TRANSISTOR DTC114ES
Q319	8-729-245-83	TRANSISTOR 2SC2458
R101	Δ 1-217-383-00	FUSIBLE 4.7 5% 1/4W F
R102	Δ 1-217-383-00	FUSIBLE 4.7 5% 1/4W F
R104	1-247-248-00	CARBON 2.2K 5% 1/2W
R105	1-247-248-00	CARBON 2.2K 5% 1/2W
R106	1-247-815-00	CARBON 220 5% 1/6W
R107	1-247-815-00	CARBON 220 5% 1/6W
R108	1-247-815-00	CARBON 220 5% 1/6W
R109	1-247-847-00	CARBON 4.7K 5% 1/6W
R110	1-247-849-00	CARBON 5.6K 5% 1/6W
R111	1-247-855-00	CARBON 10K 5% 1/6W
R112	1-247-856-00	CARBON 11K 5% 1/6W
R113	1-247-855-00	CARBON 10K 5% 1/6W

NOTE:

The mechanical parts with no reference number in the exploded views are not supplied.

Items marked "★" are not stocked since they are seldom required for routine service. Some delay should be anticipated when ordering these items.

CAPACITORS:

All capacitors are in μF . Common capacitors are omitted. Refer to the following lists for their part numbers.

MF: μF , pf: μpF .

COILS

MH: mH, UH: μH

SEMICONDUCTORS

In each case, U: μ , for example:

UA...: μA ...; UPA...: μPA ...; UPC...: μPC ...

UPD...: μPD ...

Ref.No.	Part No.	Description
---------	----------	-------------

R114	1-247-107-00	CARBON 100 5% 1/4W
R115	1-247-855-00	(US)...CARBON 10K 5% 1/6W
R201	1-247-807-00	CARBON 100 5% 1/6W
R202	1-247-887-00	CARBON 220K 5% 1/6W
R203	1-247-839-00	CARBON 2.2K 5% 1/6W
R204	1-247-839-00	CARBON 2.2K 5% 1/6W
R205	1-247-903-00	CARBON 1M 5% 1/6W
R206	1-247-855-00	CARBON 10K 5% 1/6W
R207	1-247-855-00	CARBON 10K 5% 1/6W
R208	1-247-883-00	CARBON 150K 5% 1/6W
R209	1-247-876-00	CARBON 75K 5% 1/6W
R210	1-247-855-00	CARBON 10K 5% 1/6W
R211	1-247-871-00	CARBON 47K 5% 1/6W
R212	1-247-875-00	CARBON 68K 5% 1/6W
R213	1-247-839-00	CARBON 2.2K 5% 1/6W
R214	1-247-839-00	CARBON 2.2K 5% 1/6W
R215	1-247-839-00	CARBON 2.2K 5% 1/6W
R216	1-247-839-00	CARBON 2.2K 5% 1/6W
R217	1-247-891-00	CARBON 330K 5% 1/6W
R218	1-247-891-00	CARBON 330K 5% 1/6W
R219	1-247-891-00	CARBON 330K 5% 1/6W
R220	1-247-891-00	CARBON 330K 5% 1/6W
R221	1-247-903-00	CARBON 1M 5% 1/6W
R222	1-247-903-00	CARBON 1M 5% 1/6W
R223	1-247-855-00	CARBON 10K 5% 1/6W
R224	1-247-855-00	CARBON 10K 5% 1/6W
R225	1-247-855-00	CARBON 10K 5% 1/6W
R226	1-247-855-00	CARBON 10K 5% 1/6W
R227	1-247-879-00	CARBON 100K 5% 1/6W
R228	1-247-855-00	CARBON 10K 5% 1/6W
R229	1-247-855-00	CARBON 10K 5% 1/6W
R230	1-247-771-00	CARBON 3.3 5% 1/6W
R231	1-247-771-00	CARBON 3.3 5% 1/6W
R232	1-247-801-00	CARBON 56 5% 1/6W
R233	1-247-801-00	CARBON 56 5% 1/6W
R234	1-247-831-00	CARBON 1K 5% 1/6W
R235	1-247-839-00	CARBON 2.2K 5% 1/6W
R236	1-247-839-00	CARBON 2.2K 5% 1/6W
R237	1-247-879-00	CARBON 100K 5% 1/6W
R238	1-247-855-00	CARBON 10K 5% 1/6W
R239	1-247-879-00	CARBON 100K 5% 1/6W
R240	1-247-867-00	CARBON 33K 5% 1/6W
R241	1-247-865-00	CARBON 27K 5% 1/6W
R242	1-247-855-00	CARBON 10K 5% 1/6W
R243	1-247-855-00	CARBON 10K 5% 1/6W

The components identified by shading and mark **Δ** are critical for safety. Replace only with part number specified.

ELECTRICAL PARTS

Ref.No.	Part No.	Description	100K	5%	1/6W
R244	1-247-879-00	CARBON	100K	5%	1/6W
R301	1-247-855-00	CARBON	10K	5%	1/6W
R302	1-247-855-00	CARBON	10K	5%	1/6W
R303	1-247-867-00	CARBON	33K	5%	1/6W
R304	1-247-855-00	CARBON	10K	5%	1/6W
R305	1-247-855-00	CARBON	10K	5%	1/6W
R306	1-247-847-00	CARBON	4.7K	5%	1/6W
R307	1-247-855-00	CARBON	10K	5%	1/6W
R308	1-247-847-00	CARBON	4.7K	5%	1/6W
R309	1-247-855-00	CARBON	10K	5%	1/6W
R310	1-247-847-00	CARBON	4.7K	5%	1/6W
R311	1-247-851-00	CARBON	6.8K	5%	1/6W
R312	1-247-807-00	CARBON	100	5%	1/6W
R313	1-247-848-00	CARBON	5.1K	5%	1/6W
R314	1-247-855-00	CARBON	10K	5%	1/6W
R315	1-247-855-00	CARBON	10K	5%	1/6W
R316	1-247-825-00	CARBON	560	5%	1/6W
R317	1-247-903-00	CARBON	1M	5%	1/6W
R318	1-247-879-00	CARBON	100K	5%	1/6W
R319	1-247-879-00	CARBON	100K	5%	1/6W
R320	1-247-879-00	CARBON	100K	5%	1/6W
R321	1-247-879-00	CARBON	100K	5%	1/6W
R322	1-247-831-00	CARBON	1K	5%	1/6W
R323	1-247-831-00	CARBON	1K	5%	1/6W
R324	1-247-831-00	CARBON	1K	5%	1/6W
R325	1-247-831-00	CARBON	1K	5%	1/6W
R326	1-247-831-00	CARBON	1K	5%	1/6W
R327	1-247-810-00	CARBON	130	5%	1/6W
R328	1-247-803-00	CARBON	68	5%	1/6W
R329	1-247-803-00	CARBON	68	5%	1/6W
R330	1-247-803-00	CARBON	68	5%	1/6W
R331	1-247-807-00	CARBON	100	5%	1/6W
R332	1-247-815-00	CARBON	220	5%	1/6W
R333	1-247-815-00	CARBON	220	5%	1/6W
R334	1-247-815-00	CARBON	220	5%	1/6W
R335	1-247-815-00	CARBON	220	5%	1/6W
R336	1-247-815-00	CARBON	220	5%	1/6W
R337	1-247-879-00	CARBON	100K	5%	1/6W
R338	1-247-879-00	CARBON	100K	5%	1/6W
R339	1-247-867-00	CARBON	33K	5%	1/6W
R340	1-247-865-00	CARBON	27K	5%	1/6W
R341	1-247-831-00	CARBON	1K	5%	1/6W
R342	1-247-831-00	CARBON	1K	5%	1/6W
R343	1-247-831-00	CARBON	1K	5%	1/6W
R344	1-247-831-00	CARBON	1K	5%	1/6W

ELECTRICAL PARTS

Ref.No.	Part No.	Description	330K	5%	1/6W
R345	1-247-891-00	CARBON	330K	5%	1/6W
R346	1-247-903-00	CARBON	1M	5%	1/6W
R347	1-247-867-00	CARBON	33K	5%	1/6W
R348	1-247-807-00	CARBON	100	5%	1/6W
R349	1-247-847-00	CARBON	4.7K	5%	1/6W
R350	1-247-851-00	CARBON	6.8K	5%	1/6W
R351	1-247-903-00	CARBON	1M	5%	1/6W
R352	1-247-825-00	CARBON	560	5%	1/6W
R353	1-247-813-00	CARBON	180	5%	1/6W
R354	1-247-810-00	CARBON	130	5%	1/6W
R355	1-247-822-00	CARBON	430	5%	1/6W
R356	1-247-848-00	CARBON	5.1K	5%	1/6W
R357	1-247-855-00	CARBON	10K	5%	1/6W
R359	1-247-855-00	CARBON	10K	5%	1/6W
R360	1-247-903-00	CARBON	1M	5%	1/6W
R361	1-247-867-00	CARBON	33K	5%	1/6W
R362	1-247-865-00	CARBON	27K	5%	1/6W
R363	1-247-829-00	CARBON	820	5%	1/6W
R364	1-247-863-00	CARBON	22K	5%	1/6W
R365	1-247-855-00	CARBON	10K	5%	1/6W
R366	1-247-855-00	CARBON	10K	5%	1/6W
R367	1-247-879-00	CARBON	100K	5%	1/6W
R368	1-247-867-00	CARBON	33K	5%	1/6W
R369	1-247-865-00	CARBON	27K	5%	1/6W
R370	1-247-867-00	CARBON	33K	5%	1/6W
R371	1-247-855-00	CARBON	10K	5%	1/6W
R372	1-247-855-00	CARBON	10K	5%	1/6W
R373	1-247-855-00	CARBON	10K	5%	1/6W
R374	1-247-879-00	CARBON	100K	5%	1/6W
R375	1-247-867-00	CARBON	33K	5%	1/6W
R376	1-247-865-00	CARBON	27K	5%	1/6W
R377	1-247-883-00	CARBON	150K	5%	1/6W
R378	1-247-879-00	CARBON	100K	5%	1/6W
R379	1-247-879-00	CARBON	100K	5%	1/6W
R380	1-247-891-00	CARBON	330K	5%	1/6W
R381	1-247-887-00	CARBON	220K	5%	1/6W
R382	1-247-891-00	CARBON	330K	5%	1/6W
R383	1-247-887-00	CARBON	220K	5%	1/6W
R384	1-247-887-00	CARBON	220K	5%	1/6W
R385	1-247-887-00	CARBON	220K	5%	1/6W
R386	1-247-771-00	CARBON	3.3	5%	1/6W
R387	1-247-771-00	CARBON	3.3	5%	1/6W
R388	1-247-795-00	CARBON	33	5%	1/6W
R389	1-247-795-00	CARBON	33	5%	1/6W

NOTE:

The mechanical parts with no reference number in the exploded views are not supplied.

Items marked " * " are not stocked since they are seldom required for routine service. Some delay should be anticipated when ordering these items.

CAPACITORS:

All capacitors are in μF . Common capacitors are omitted. Refer to the following lists for their part numbers.

MF: μF , PF: pF.

COILS

MH: mH, UH: μH

SEMICONDUCTORS

In each case, U: μ , for example: UA...: μA ...; UPA...: μPA ...; UPC...: μPC ; UPD...: μPD ...

ELECTRICAL PARTS

ELECTRICAL PARTS

Ref.No. Part No. Description

R390	1-247-807-00	CARBON	100	5%	1/6W
R391	1-247-807-00	CARBON	100	5%	1/6W
R392	1-247-867-00	CARBON	33K	5%	1/6W
R393	1-247-867-00	CARBON	33K	5%	1/6W
R394	1-247-879-00	CARBON	100K	5%	1/6W
R395	1-247-855-00	CARBON	100K	5%	1/6W
R396	1-247-855-00	CARBON	10K	5%	1/6W
R397	1-247-887-00	CARBON	220K	5%	1/6W
R398	1-247-879-00	CARBON	100K	5%	1/6W
R399	1-247-831-00	CARBON	1K	5%	1/6W
R400	1-247-879-00	CARBON	100K	5%	1/6W
R401	1-247-815-00	CARBON	220	5%	1/6W
R402	1-247-855-00	CARBON	10K	5%	1/6W
R403	1-247-831-00	CARBON	1K	5%	1/6W
R404	1-247-823-00	CARBON	470	5%	1/6W
R405	1-247-863-00	CARBON	22K	5%	1/6W
R406	1-247-863-00	CARBON	22K	5%	1/6W
R407	1-247-855-00	CARBON	10K	5%	1/6W
R408	1-247-815-00	CARBON	220	5%	1/6W
R409	1-247-855-00	CARBON	10K	5%	1/6W
R410	1-247-775-00	CARBON	4.7	5%	1/6W
R411	1-247-871-00	CARBON	47K	5%	1/6W
R412	1-247-847-00	CARBON	4.7K	5%	1/6W
R413	1-247-847-00	CARBON	4.7K	5%	1/6W
R414	1-247-847-00	CARBON	4.7K	5%	1/6W
R415	1-247-855-00	CARBON	10K	5%	1/6W
R416	1-247-855-00	CARBON	10K	5%	1/6W
R417	1-247-855-00	CARBON	10K	5%	1/6W
R418	1-247-855-00	CARBON	10K	5%	1/6W
R419	1-247-903-00	CARBON	1M	5%	1/6W
R420	1-247-879-00	(US)...CARBON	100K	5%	1/6W
R421	1-247-879-00	(US)...CARBON	100K	5%	1/6W
R422	1-247-879-00	(US)...CARBON	100K	5%	1/6W
R423	1-247-825-00	CARBON	560	5%	1/6W
R424	1-247-897-00	CARBON	560K	5%	1/6W
R425	1-247-897-00	CARBON	560K	5%	1/6W
R426	1-247-899-00	CARBON	680K	5%	1/6W
R427	1-247-843-00	(US)...CARBON	3.3K	5%	1/6W
R428	1-247-843-00	(US)...CARBON	3.3K	5%	1/6W
R429	1-247-843-00	(US)...CARBON	3.3K	5%	1/6W
R501	1-247-815-00	CARBON	220	5%	1/6W
R502	1-247-815-00	CARBON	220	5%	1/6W
R503	1-247-819-00	CARBON	330	5%	1/6W
RV201	1-226-234-00	RES, ADJ, CARBON 2K			
RV202	1-226-234-00	RES, ADJ, CARBON 2K			
RV301	1-228-542-00	RES, ADJ, METAL GLAZE 10K			

Ref.No. Part No. Description

RV302	1-228-542-00	RES, ADJ, METAL GLAZE 10K			
RV303	1-224-256-XX	RES, ADJ, METAL GLAZE 220K			
RV304	1-224-134-XX	RES, ADJ, METAL GLAZE 470K			
RY501	1-515-519-00	RELAY			
S101	1-552-928-00	SWITCH (POWER)			
S301	1-554-088-00	SWITCH, KEY BOARD (OPEN/CLOSE)			
S302	1-554-088-00	SWITCH, KEY BOARD (START/STOP)			
S303	1-554-088-00	SWITCH, KEY BOARD (BACKWARD)			
S304	1-554-088-00	SWITCH, KEY BOARD (FORWARD)			
S305	1-554-088-00	SWITCH, KEY BOARD (UP/DOWN)			
S306	1-554-088-00	SWITCH, KEY BOARD (REPEAT)			
S307	1-554-088-00	SWITCH, KEY BOARD (SPEED)			
S308	1-554-088-00	SWITCH, KEY BOARD (SKIP)			
S309	1-554-088-00	SWITCH, KEY BOARD (CLEAR)			
S310	1-554-088-00	SWITCH, KEY BOARD (RMS 9)			
S311	1-554-088-00	SWITCH, KEY BOARD (RMS 8)			
S312	1-554-088-00	SWITCH, KEY BOARD (RMS 7)			
S313	1-554-088-00	SWITCH, KEY BOARD (RMS 6)			
S314	1-554-088-00	SWITCH, KEY BOARD (RMS 5)			
S315	1-554-088-00	SWITCH, KEY BOARD (RMS 4)			
S316	1-554-088-00	SWITCH, KEY BOARD (RMS 3)			
S317	1-554-088-00	SWITCH, KEY BOARD (RMS 2)			
S318	1-554-088-00	SWITCH, KEY BOARD (RMS 1)			
S319	1-552-339-00	SWITCH, SLIDE (SENS.)			
SW501	1-554-205-00	SWITCH, PUSH (CLOSE DET.)			
SW502	1-554-205-00	SWITCH, PUSH (OPEN DET.)			
SW601	1-554-921-11	SWITCH, MICRO (REST POINT DET.)			

T901 A.1-447-860-11 (AEP)...TRANSFORMER, POWER

T901 Δ.1-447-859-11 (US)...TRANSFORMER, POWER

TP1 *1-564-113-11 PIN, CONNECTOR 4P

TP2 *1-564-113-11 PIN, CONNECTOR 4P

X201 1-567-259-11 VIBRATOR, CRYSTAL

X301 1-567-192-11 OSCILLATOR, CERAMIC

NOTE:

The mechanical parts with no reference number in the exploded views are not supplied.

Items marked "★" are not stocked since they are seldom required for routine service. Some delay should be anticipated when ordering these items.

CAPACITORS:

All capacitors are in μF . Common capacitors are omitted. Refer to the following lists for their part numbers.

MF: μF , PF: μpF .

COILS

MH: mH, UH: μH

SEMICONDUCTORS

In each case, U: μ , for example:UA...: μA ..., UPA...: μPA ..., UPC...: μPC .UPD...: μPD ...

The components identified by shading and mark **A** are critical for safety. Replace only with part number specified.

9-951-433-11

Sony Corporation

1984

—52—

English
84E0589-1

Printed in Japan